

NOTE: CLIP SHIM IS REQUIRED WHEN THE FOLLOWING CLIPS ARE TO BE USED IN CONJUNCTION WITH THICK WEB POINTS:
 MJS CLIPS: 352 J 352 K ROCKER CLIPS: 352 O 352 N

CLIP SHIM
 GTS-343 E

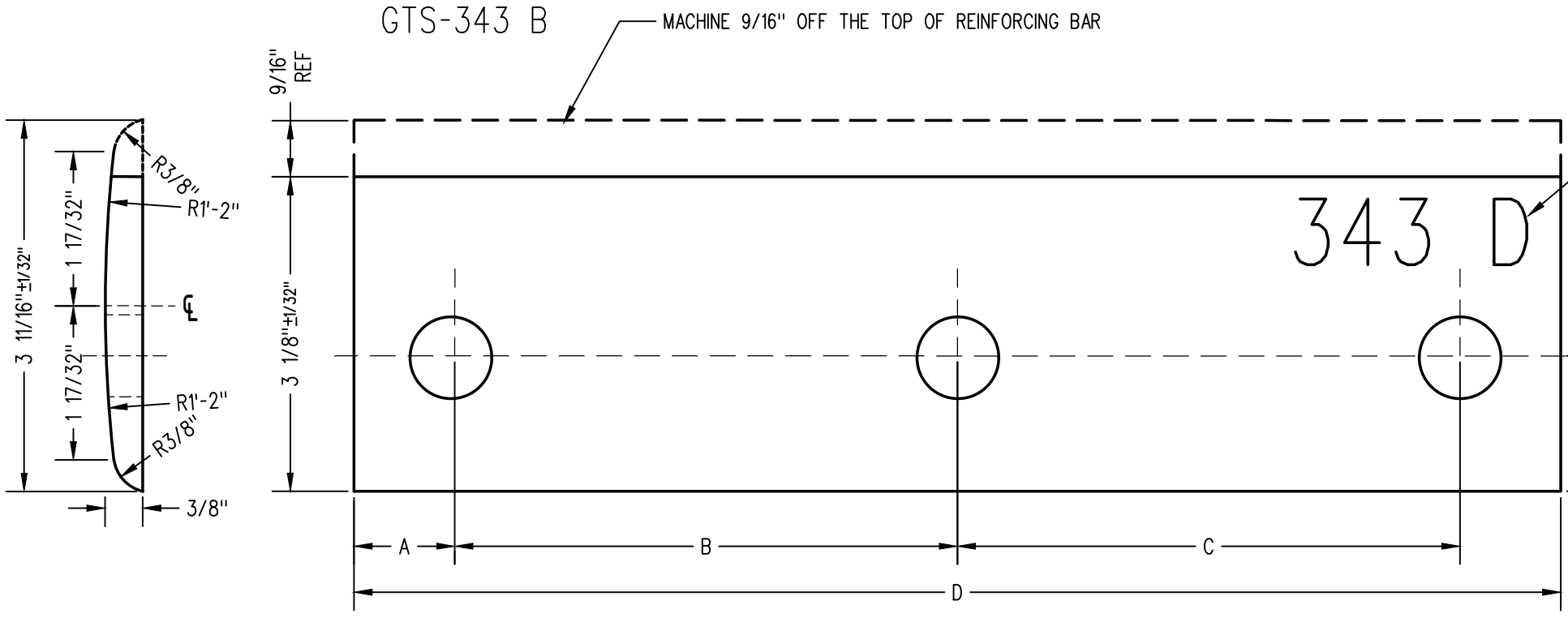

1/2" MINIMUM IDENTIFICATION CHARACTERS TO BE STAMPED PLAINLY ON FLAT SIDE SHIM

NOTES:

1. ALL DIMENSIONS ARE IN INCHES.
2. ALL SHIMS TO BE MADE OUT OF ROLLED STEEL STANDARD REFERRING TO REINFORCING BARS STOCK, AS SHOWN IN TABLE.
3. ALL SHIMS TO BE DRILLED
4. WHEN REFERRING TO SHIMS DRAWING NUMBER MUST BE STATED AS GTS-343 A, B, C OR D TO INDICATE SPECIFIC SHIM REQUIRED

ITEM	A	B +1/16	C +1/16	D	E (DIA)	REONFORCMENT BAR DRAWING NUMBER
GTS-343 A	1	5	-	7	13/16	GTS-342 D.E OR F
GTS-343 C	1-3/4	-	-	3 1/2	13/16	GTS-342 D.E OR F
GTS-343 D	1	5	5	12	13/16	GTS-342 D.E OR F

METRIC CONVERSION: 1 inch=25.4mm, 1 foot=304.8mm

1	18/07/27	ADDED IMPERIAL TO METRIC CONVERSION NOTE	
No.	Date	Revision	By Approved
Standard		SWITCH POINT SHIMS	
FOR MOUNTING CLIPS AND LOCKS			
Drawn	MG	Checked	GGS
Approved		VP Engineering & Asset Management	



Date DEC 15, 2017 Plan Number GTS-0343 Rev 1