

SIGN BLANKS

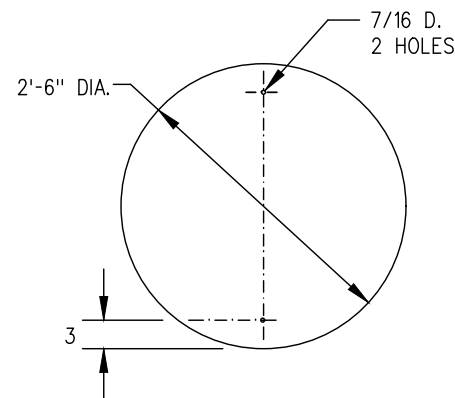

CIRCLE  
WT. : 5.75 LB.

MANUFACTURING DETAILS

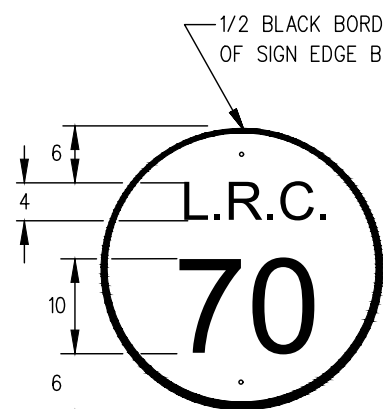

ADVANCE SPEED  
RESTRICTION SIGN

BACKGROUND: REFLECTIVE SILVER  
NUMBERS & LETTERS:  
SILK SCREENED BLACK  
OR VINYL SHEETING  
NUMBERS & LETTERS TO BE OF  
"STANDARD MEDIUM" ALPHABET.

ADVANCE SPEED RESTRICTION SIGNS WILL BE PLACED  
3000 YARDS IN ADVANCE OF SPEED RESTRICTION POINT.

LOCATION

NOTES :

GENERAL :

1. WHEN REQUISITIONING SIGNS, QUANTITY, STOCK NUMBER AND CHARACTERISTICS (WHEN REQUIRED) MUST BE INDICATED ON REQUISITION. HARDWARE MUST ALSO BE ORDERED ACCORDING TO ILLUSTRATIONS SHOWING THE NUMBER OF BOLT HOLES PER SIGN.
2. FULL SIZE SIGN TEMPLATES AVAILABLE UPON REQUEST.

MATERIALS:

1. SIGN BLANKS TO BE ALUMINUM SHEET, ALLOY 3003, H14 (12 GA.) MILL FINISH.
2. REFLECTIVE SHEETING MUST CONFORM TO THE LATEST ISSUE OF CANADIAN GENERAL STANDARDS BOARD (CGSB) STANDARD 62-GP-11 M, LEVEL 1 MATERIAL.
3. VINYL SHEETING MUST CONFORM TO THE LATEST ISSUE OF CANADIAN GENERAL STANDARDS BOARD (CGSB) STANDARD 62-GP-3M MATERIAL.

MANUFACTURING :

1. UNLESS OTHERWISE STATED, COLOR SHEETING AND SYMBOLS ARE APPLIED ON ONE SIDE ONLY.
2. ALL DIMENSIONS ARE IN INCHES.
3. ALL HOLES TO BE PUNCHED OR DRILLED.
4. ALUMINUM UNPAINTED SURFACE MUST BE THOROUGHLY DEGREASED, ETCHED, AND RINSED.
5. SHEETING TO BE APPLIED DIRECTLY TO THE PREPARED ALUMINUM SURFACE.

ERECTION :

1. UNLESS OTHERWISE INDICATED IN THE DESCRIPTION OF LOCATING AND ERECTING REMARKS:
  - A.- ALL SIGNS SHALL BE ERECTED AT RIGHT ANGLES TO TRACK WHICH THEY GOVERN.
  - B.- WHEN ERECTING SIGNS ON TWO (OR MORE) TRACKS AND EACH TRACK HAS DOUBLE DIRECTION TRAFFIC, SIGNS ARE TO LOCATED ON THE FIELD SIDE OF EACH EXTREME OUTSIDE TRACK.
  - C.- ALL SIGNS SHALL BE ERECTED 10 TO 25 FEET FROM THE GAUGE SIDE OF THE NEAREST RAIL TO THE RIGHT OF THE TRACK AS VIEWED FROM AN APPROACHING TRAIN. IN RESTRICTED SIDE CLEARANCE AREAS, THE MINIMUM DISTANCE OF 6 FEET FROM GAUGE SIDE OF THE NEAREST RAIL TO ANY PORTION OF THE SIGN MUST BE MET WITH CONSIDERATION GIVEN TO CURVED AND SUPERELEVATED FEATURES.
  - D.- ALL SIGNS SHALL BE AT A MINIMUM OF 8 FEET FROM TOP OF RAIL TO THE CENTRE LINE OF THE LOWEST SIGN ON THE POST.
  - E.- ALL SIGNS SHALL BE MOUNTED ON THE STANDARD " U " POST FOR TRACK SIGNS, UNLESS OTHERWISE SPECIFIED.
  - F.- ALL POSTS MUST PENETRATE GROUND A MINIMUM OF 4 FEET.
2. ALL SIGNS SHALL BE LOCATED AND ERECTED IN A MANNER THAT WILL AFFORD THE MOST ADVANTAGEOUS VIEW FROM AN APPROACHING TRAIN.

INCREASING ZONE SPEED SIGNS INDICATE AN INCREASE IN ZONE SPEED AND WILL BE PLACED AT THE BEGINNING OF THE SPEED ZONE TO INDICATE MAXIMUM ALLOWABLE SPEED WITHIN THE LIMITS OF THE OF THE ZONE IDENTIFIED IN THE TIME TABLE.

DECREASING ZONE SPEED SIGNS INDICATE A REDUCTION IN ZONE SPEED AND WILL BE PLACED 3000 YARDS IN ADVANCE OF THE SPEED RESTRICTION POINT TO INDICATE MAXIMUM ALLOWABLE SPEED WITHIN THE LIMITS OF THE ZONE IDENTIFIED IN THE TIME TABLE.

INCREASING AND DECREASING SPEED ZONE SIGNS WILL NOT BE PLACED:  
- IN TERMINALS  
- ON SUBDIVISIONS WHICH HAVE ONE SPEED ZONE.  
- ON SUBDIVISIONS WITH A MAXIMUM SPEED OF 30 MPH OR LESS.

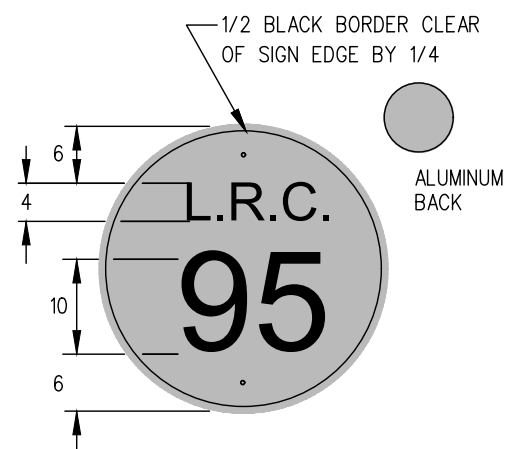

DECREASING  
ZONE SPEED  
SIGN

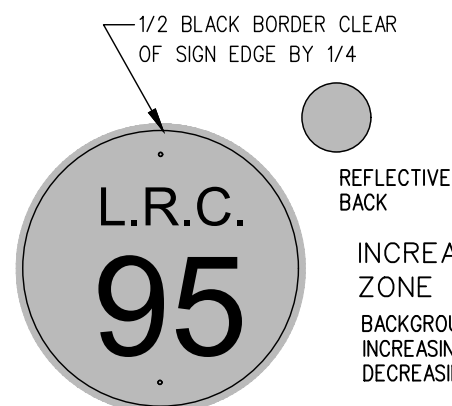

INCREASING  
ZONE SPEED  
SIGN

INCREASING/DECREASING  
ZONE SPEED SIGN  
BACKGROUND - REFLECTIVE YELLOW:  
INCREASING: BOTH SIDES  
DECREASING: FRONT SIDE ONLY

NUMBERS & LETTERS:  
SILK SCREENED BLACK  
OR VINYL SHEETING  
NUMBERS & LETTERS TO BE OF  
"STANDARD MEDIUM" ALPHABET.

ITEM NO.	DESCRIPTION	PLAN NUMBER
1	KIT SIGN MOUNTING ASSEMBLY	
2	SIGN (STATE TYPE AND STOCK NUMBER)	GTS-0720
3	" U " POST FOR TRACK SIGNS	GTS-0719
4	BLOCK FILLER FOR POST ( CAST OR FORMED )	GTS-0719
5	FIBRE WASHER 3/8 I.D. x 5/8 O.D. x 1/16 THICK	—
6	3/8 DIA.-16 UNC RD. CAP SCREW 2-1/2 LG. C/W SQ. NUT	—
7	SPRING WASHER HELICAL FOR 3/8 CAP SCREW, PLATED	—
	PLATE WASHER 7/16 I.D. x 1 O.D. x 5/64 THICK, PLATED	—

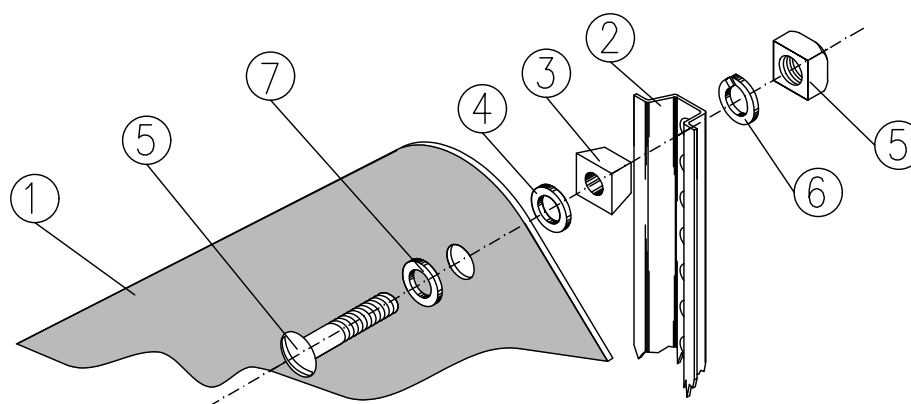

METRIC CONVERSION: 1 inch=25.4mm, 1 foot=304.8mm

1	18/07/27	ADDED IMPERIAL TO METRIC CONVERSION NOTE	
No.	Date	Revision	By Approved
Standard/		SIGNS	
Drawn	MG	Checked	GGS
Approved		VP Engineering & Asset Management	
Date		SEPT 15/2017	Plan Number GTS-0720 Rev 1
REFERENCE: TS-0720_SH16_R4		Sheet 16 OF 41	