

SIGN BLANKS

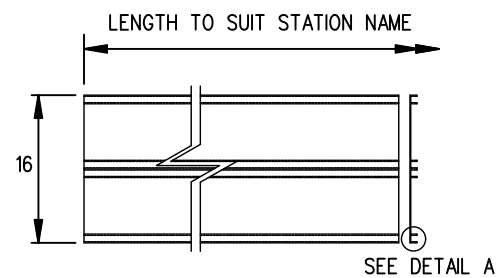

RECTANGLE

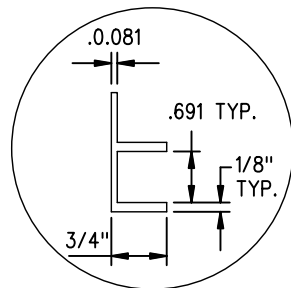

DETAIL A

MANUFACTURING DETAILS

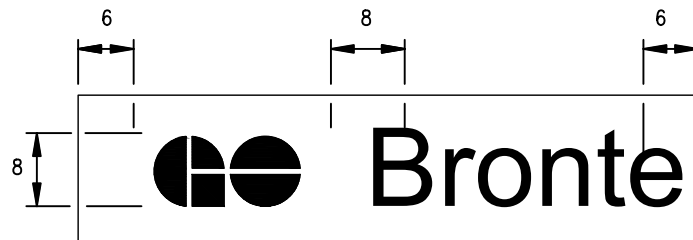

STATION NAME SIGN

(ONE WORD)

SIGN BLANK: TWO-REYNOLDS ALUMINUM CANADA 8" WIDE EXTRUSIONS NO. B 36 N DIE 71537 OF SUITABLE LENGTH. THE TWO EXTRUSIONS ARE TO BE BOLTED TOGETHER WITH * 10-32 X 1/2" LONG ROUND HEAD BRASS SCREWS WITH ESNA NUTS AT 5" CENTRES.

BACKGROUND: MATTE VINYL WHITE
 SYMBOL: MATTE VINYL BLACK
 LETTERS: MATTE VINYL BLACK "STANDARD MEDIUM ALPHABET"

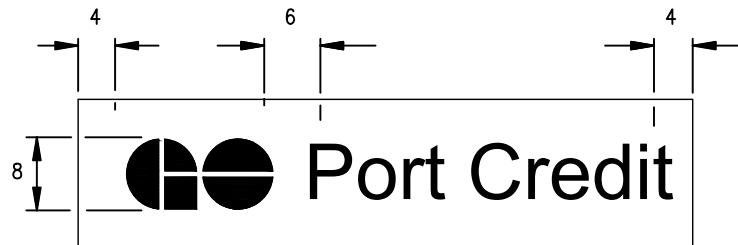

STATION NAME SIGN

(TWO WORDS)

ALTERNATIVE LAYOUT - WHEN SIGN LENGTH EXCEEDS 8' DUE TO TWO WORD STATION NAME.
 BACKGROUND: MATTE VINYL WHITE
 SYMBOL: MATTE VINYL BLACK
 LETTERS: MATTE VINYL BLACK "STANDARD MEDIUM ALPHABET"

LOCATION

STATION NAME SIGNS ARE TO BE LOCATED AT THE SUBDIVISION STATION MILEAGE POINT SHOWN IN THE TIMETABLE. SIGNS TO BE ERECTED AT A MINIMUM DISTANCE OF 20 FEET FROM CENTRE LINE OF MAIN TRACK AND ON THE OPPOSITE SIDE TO THE PASSING TRACK. SIGN TO HAVE TWO BLADES FRONT AND BACK OF POSTS.

STATION NAME SIGNS ARE TO BE LOCATED AT THE SUBDIVISION STATION MILEAGE POINT SHOWN IN THE TIMETABLE. SIGNS TO BE ERECTED AT A MINIMUM DISTANCE OF 20 FEET FROM CENTRE LINE OF MAIN TRACK AND ON THE OPPOSITE SIDE TO THE PASSING TRACK. SIGN TO HAVE TWO BLADES FRONT AND BACK OF POSTS.

NOTES :

GENERAL :

1. WHEN REQUISITIONING SIGNS, QUANTITY, STOCK NUMBER AND CHARACTERISTICS (WHEN REQUIRED) MUST BE INDICATED ON REQUISITION. HARDWARE MUST ALSO BE ORDERED ACCORDING TO ILLUSTRATIONS SHOWING THE NUMBER OF BOLT HOLES PER SIGN.
2. FULL SIZE SIGN TEMPLATES AVAILABLE UPON REQUEST.

MATERIALS:

1. SIGN BLANKS TO BE ALUMINUM SHEET, ALLOY 3003, H14 (12 GA.) MILL FINISH.
2. VINYL SHEETING MUST CONFORM TO THE LATEST ISSUE OF CANADIAN GENERAL STANDARDS BOARD (CGSB) STANDARD 62-GP- 3M MATERIAL.

MANUFACTURING :

1. UNLESS OTHERWISE STATED, COLOR SHEETING AND SYMBOLS ARE APPLIED ON ONE SIDE ONLY.
2. ALL DIMENSIONS ARE IN INCHES.
3. ALL HOLES TO BE PUNCHED OR DRILLED.
4. ALUMINUM UNPAINTED SURFACE MUST BE THOROUGHLY DEGREASED, ETCHED, AND RINSED.
5. SHEETING TO BE APPLIED DIRECTLY TO THE PREPARED ALUMINUM SURFACE.

ERECTION :

1. UNLESS OTHERWISE INDICATED IN THE DESCRIPTION OF LOCATING AND ERECTING REMARKS:
 - A.- ALL SIGNS SHALL BE ERECTED AT RIGHT ANGLES TO TRACK WHICH THEY GOVERN.
 - B.-WHEN ERECTING SIGNS ON TWO (OR MORE) TRACKS AND EACH TRACK HAS DOUBLE DIRECTION TRAFFIC, SIGNS ARE TO BE LOCATED ON THE FIELD SIDE OF EACH EXTREME OUTSIDE TRACK.
 - C.- ALL SIGNS SHALL BE ERECTED 10 TO 25 FEET FROM THE GAUGE SIDE OF THE NEAREST RAIL TO THE RIGHT OF THE TRACK AS VIEWED FROM AN APPROACHING TRAIN. IN RESTRICTED SIDE CLEARANCE AREAS, THE MINIMUM DISTANCE OF 6 FEET FROM GAUGE SIDE OF THE NEAREST RAIL TO ANY PORTION OF THE SIGN MUST BE MET WITH CONSIDERATION GIVEN TO CURVED AND SUPERELEVATED FEATURES.
 - D.- ALL SIGNS SHALL BE AT A MINIMUM OF 8 FEET FROM TOP OF RAIL TO THE CENTRE LINE OF THE LOWEST SIGN ON THE POST.
 - E.- ALL SIGNS SHALL BE MOUNTED ON THE STANDARD " U " POST FOR TRACK SIGNS, UNLESS OTHERWISE SPECIFIED.
 - F.- ALL POSTS MUST PENETRATE GROUND A MINIMUM OF 4 FEET.
2. ALL SIGNS SHALL BE LOCATED AND ERECTED IN A MANNER THAT WILL AFFORD THE MOST ADVANTAGEOUS VIEW FROM AN APPROACHING TRAIN.

ITEM NO.	DESCRIPTION	PLAN NUMBER
1	SIGN (STATE TYPE AND STOCK NUMBER)	GTS-0720
2	" U " POST FOR TRACK SIGNS	GTS-0719
3	BLOCK FILLER FOR POST (CAST OR FORMED)	GTS-0719
4	FIBRE WASHER 3/8 I.D. x 5/8 O.D. x 1/16 THICK	—
5	3/8 DIA.-16 UNC RD. CAP SCREW 2-1/2 LG. C/W SQ. NUT	—
6	SPRING WASHER HELICAL FOR 3/8 CAP SCREW, PLATED	—
7	PLATE WASHER 7/16 I.D. x 1 O.D. x 5/64 THICK, PLATED	—

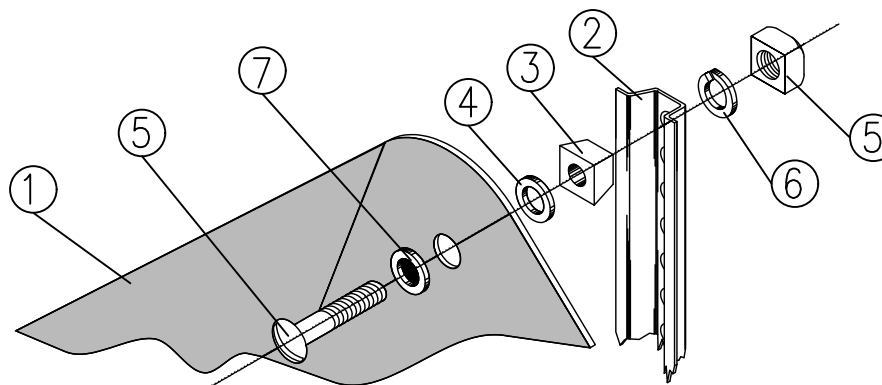

METRIC CONVERSION: 1 inch=25.4mm, 1 foot=304.8mm

1	18/07/27	ADDED IMPERIAL TO METRIC CONVERSION NOTE	
No.	Date	Revision	By Approved

Standard / **SIGNS**

Drawn MG Checked GGS Approved *[Signature]*
 VP Engineering & Asset Management



Date SEPT 15/2017 Plan Number GTS-0720 Rev 1