

ROD	POSITION FROM POINT OF SWITCH
1	1'5"
2	4'6"

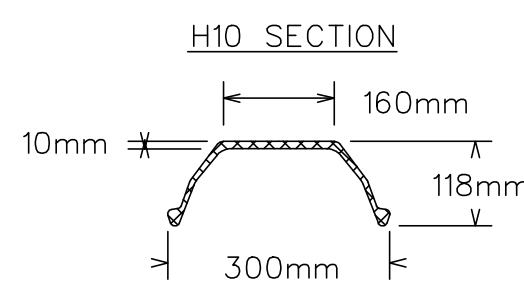

SECTION PROPERTIES
 WEIGHT OF BAR: 30.8kg/m
 YIELD STRENGTH: 345MPa (min)
 SECTION MODUL II: Z TOP-153 X 10³ mm³
 : Z BOT-79.7 X 10³ mm³

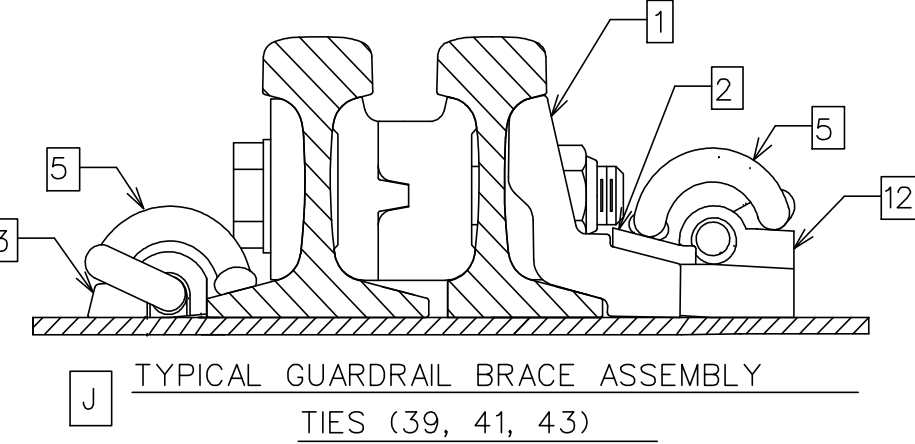
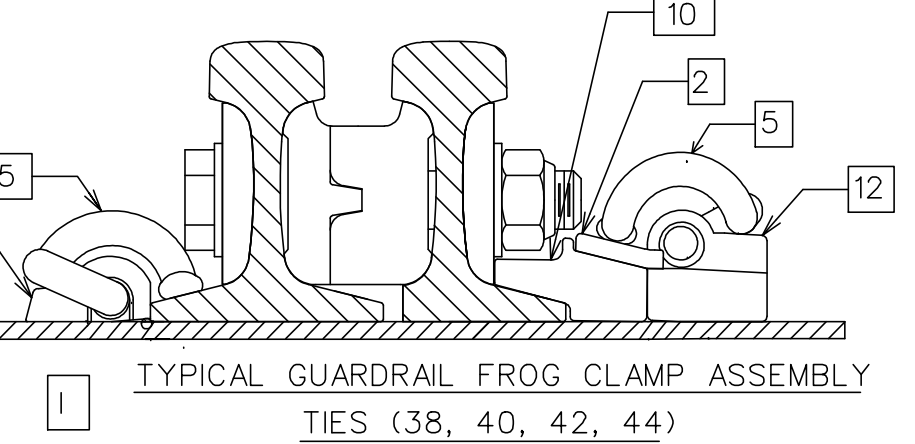
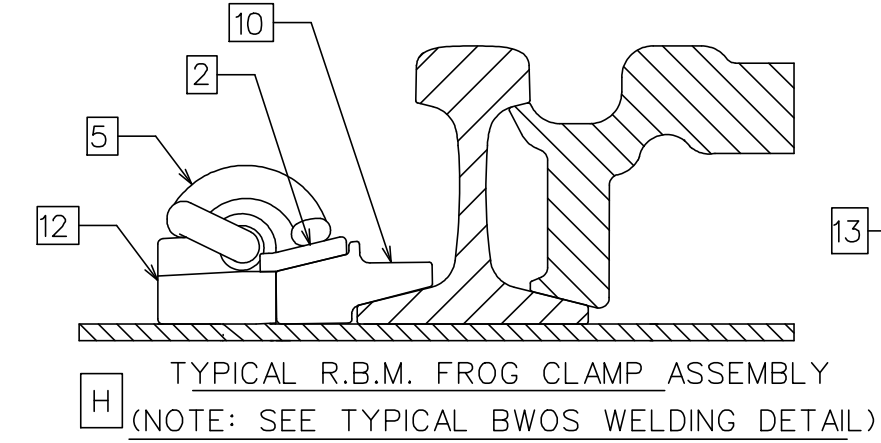
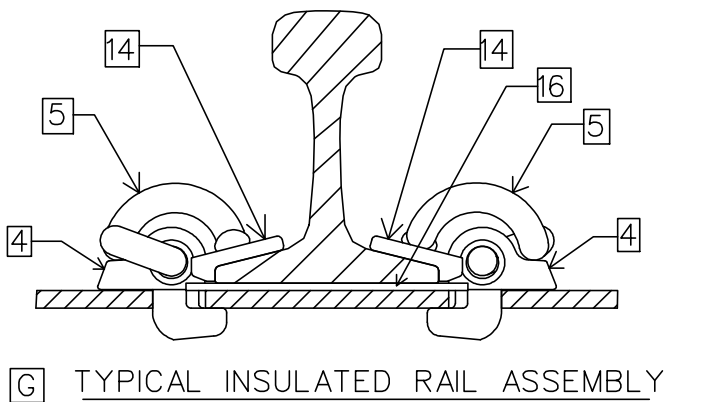
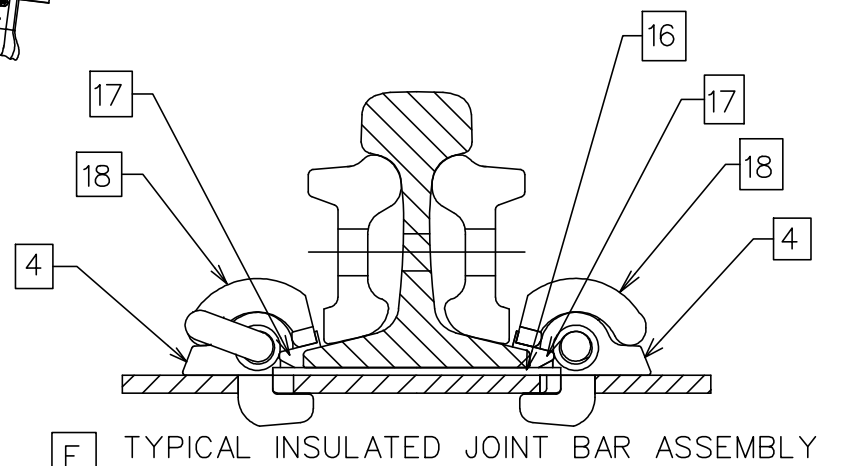
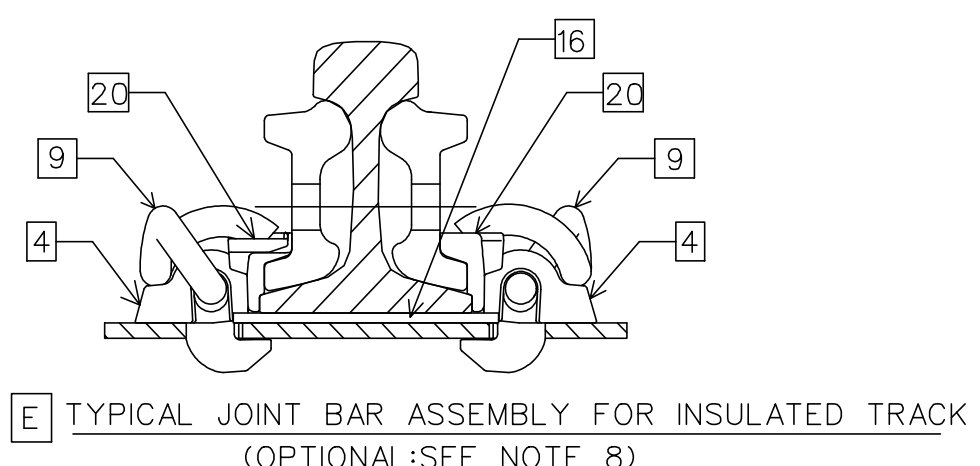
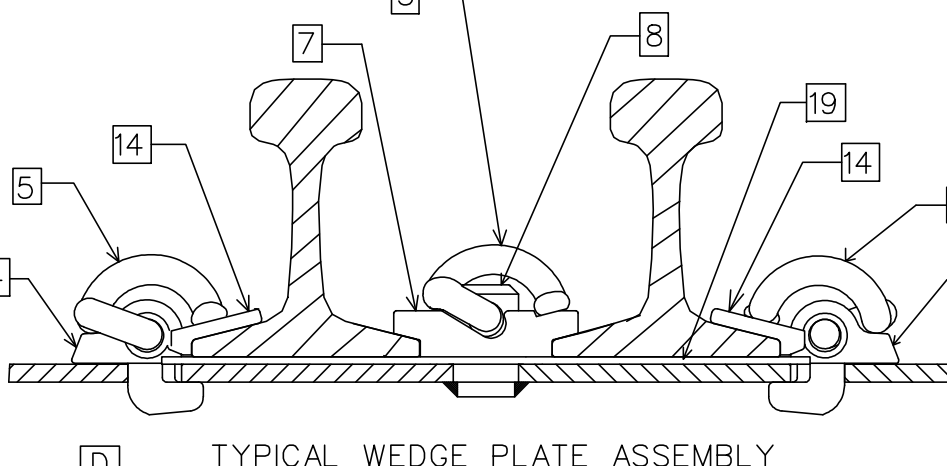
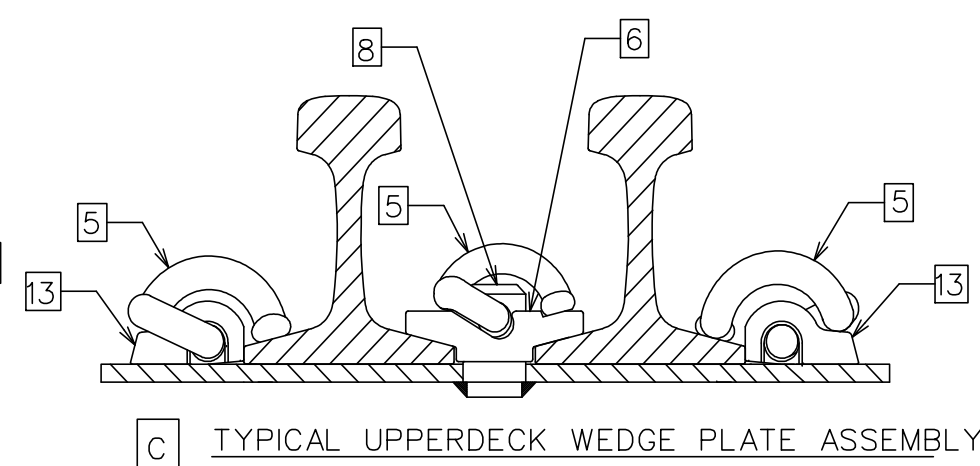
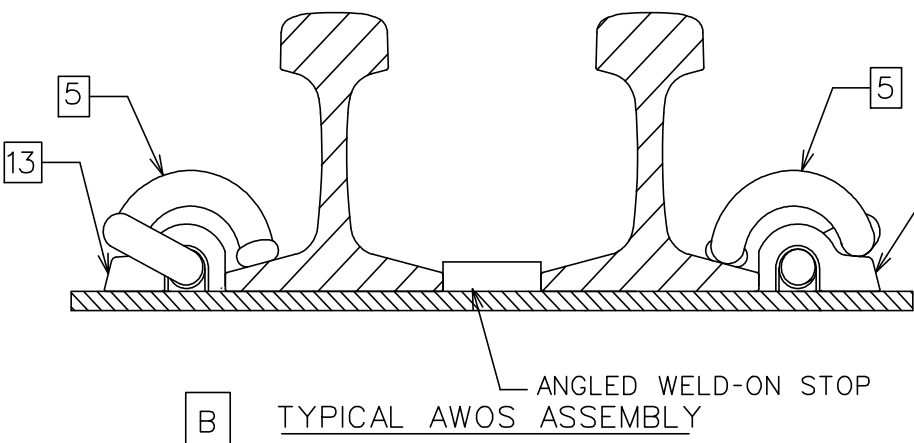
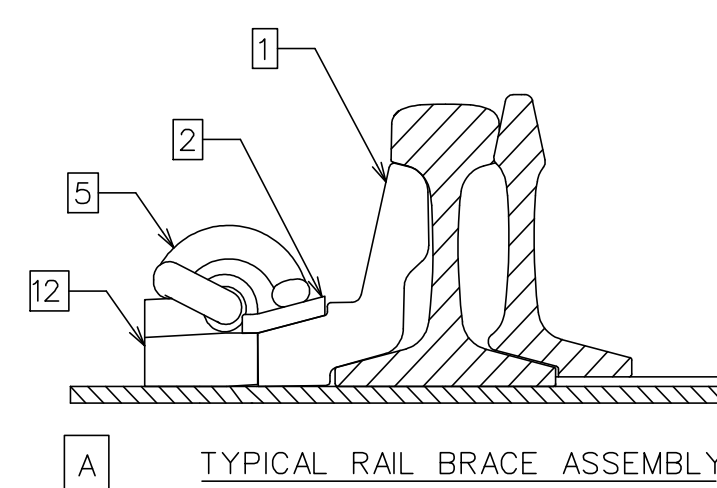
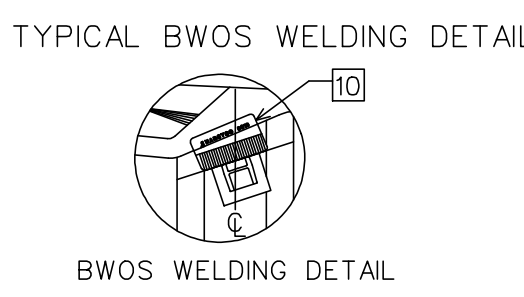

IN PRACTICE:
 - LOCATE 8017 FROG CLAMP AS SHOWN IN DETAIL
 - PLACE BWOS AGAINST FROG CLAMP ON TIE CENTER
 - TRACK WELD BWOS IN PLACE
 - USING 7018 WELDING ROD, 3/16" OR BIGGER, PLACE 1/2" FILLET WELD ON OUTSIDE EDGES OF BWOS
 - DRIVE 8017 FROG CLAMP IN FROM RIGHTHAND SIDE
 - INSTALL SERRATED WASHER AND THEN CLIP
 - FOR MORE DETAILED INSTRUCTIONS, SEE S.O.P MG 045

TIE BUNDLE LABEL FORMAT

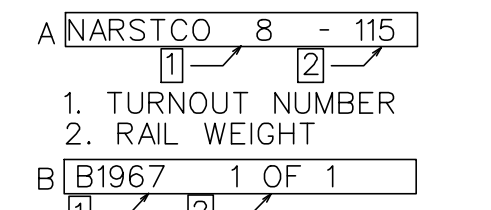

TIE MARKINGS

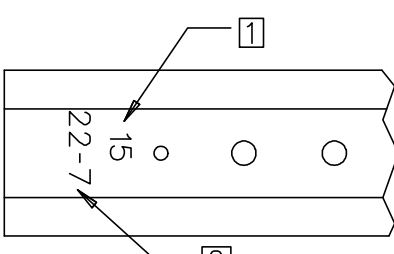

- NOTE:
- TRANSITION TIES ARE FLAT SEAT DESIGN (NO CANT) REF. GTS-2106.
 - LABELS A, B & C AFFIXED TO TOP TIE IN EVERY BUNDLE ONLY.
 - TO AVOID VARIANCE IN RAIL GAUGE, DUE TO RAIL HEAD TO BASE ECCENTRICITY, ENSURE THAT THE RAIL BRAND OF ALL RAILS FACES IN THE SAME DIRECTION.
 - a. UNIFORM RISER PLATE THICKNESS:
 - 1/4" FOR TIES 2 TO 12
 - 3/16" FOR TIE 13
 - 1/8" FOR TIE 14
 - 1/16" FOR TIE 15
 - b. UNIFORM RISER PLATES SHALL CONFORM WITH LATEST ISSUES OF ASTM A36.
 - TIES WILL BE PUNCHED FOR 7/8" DIA. INSPECTION HOLES, LOCATION VARIES WITH RAIL POSITION.
 - POINT AND FROG AREA TIES ARE NARSTCO PATENTED INSULATED MULTI-STACK DESIGN. NARSTCO PATENT NO.7731099.
 - USE OFF-SET RAIL PADS IN RAIL SEATS FOR TIES WITH HOLES PUNCHED OFF CENTER. (TIES 17, 18, 38 & 47)
 - JOINT BARS SHOULD BE USED AS NECESSARY, JOINTS CAN BE WELDED TO PRODUCE CONTINUOUS RAIL IF REQUIRED.
 - ADJUSTABLE MJ CLIPS WITH VERTICAL SWITCH RODS SHOULD BE USED IN CHANNEL TIES.
 - TIES 51-58 ARE 15' OR OVER IN LENGTH.
 - TRANSITION TIES NOT INCLUDED IN TURNOUT PACKAGE.
 - IF ZERO POINT SWITCH POINTS ARE USED, A NOMINAL 3/8" WIDE GAUGE WILL OCCUR AT THE POINT OF SWITCH AND WILL TAPER BACK TO STANDARD GAUGE THROUGH THE SWITCH AREA BEFORE THE HEEL.
 - HEADBLOCK TIES ARE FIELD-DRILLED TO ACCEPT POWER OR MANUAL SWITCH STANDS.
 - MECHANICAL JOINT LOCATIONS TO BE FIELD WELDED OR REMAIN AS STANDARD JOINTS AS DIRECTED BY METROLINX.
 - INSULATED JOINT LOCATIONS TO BE INSTALLED WHEN TRACK CIRCUITS EXIST OR ARE REQUIRED AND SHALL BE THE CONTINUOUS GLUED TYPE WITH THE INSULATED JOINT UNDRILLED (BLANKED) RAIL ENDS FIELD WELDED.

TURNOUT DATA			
FROG R.B.M.	NUMBER	8	
	ANGLE	TOE	7°09'10"
		HEEL	5'0"
		TOTAL	13'0"
SPREAD	TOE	7"	
	HEEL	1'0 1/2"	
	TANGENT ADJACENT TO TOE OF FROG	3"	
SWITCH	TANGENT ADJACENT TO HEEL OF SWITCH	0"	
	LENGTH	16'6"	
	HEEL SPREAD	6 1/4"	
	ANGLE	1°42'01"	
	VERTEX DISTANCE	1'0 5/8"	
	THROW	4 3/4"	
TURNOUT	ACTUAL LEAD	67'10 3/4"	
	CURVE ON CENTER LINE	DEGREE	11°50'42"
		RADIUS	484'6 27/32"
TRACK GAUGE	CLOSURE	STRAIGHT	46'4 3/4"
		CURVED	46'6 1/16"

METRIC CONVERSION: 1 inch=25.4mm, 1 foot=304.8mm

0	18/12/23	DWG VERSION ESTABLISHED
No.	Date	Revision
		By Approved

Standard GO TRANSIT #8-115b INS CT SPP PS
 UNIFORM FXHL RBM 13' GUARD RAIL

Drawn MR. C Checked GWM Approved VP Engineering & Asset Management



Date DEC 23/2018 Plan Number GTS-2715 Rev 0

REFERENCE: Sheet 1 OF 1

BILL OF MATERIALS FOR GTS-2715

ITEM	DESCRIPTION	NARSTCO PART NO.	QTY
TURNOUT COMPONENT			
1	ADJUSTABLE RAIL BRACE	8014	18
2	RAIL BRACE SERRATED WASHER	8015	44
3#	RAIL BRACE HOOK-IN SHOULDER	8016	110
4	NARSTCO HOOK-IN SHOULDER	4010	266
5	'e' CLIP ('e' TYPE CLIP)	'e' CLIP	484
6	STEEL WEDGE PLATE	14S,14T,15S, 15T	4
7*	NYLON WEDGE PLATE	16S,16T	2
8	WEDGE PLATE PIN	14,15,16	6
9	'J' CLIP	NJ1	32
10	FROG CLAMP (R.B.M.)	8017	24
11*	L/H 'e' CLIP	Ne2	5
12*	RAIL BRACE WELD-ON SHOULDER	BWOS	44
13	WELD-ON SHOULDER	WOS	58
14	INSULATOR	HD-10	376
15	OFFSET INSULATING PAD 5 1/2"	3020	10
16	NARSTCO INSULATING PAD 5 1/2"	IN-0030	124
17	INSULATED JOINT INSULATOR	J7819	8
18	INSULATED JOINT CLIP	e2063	8
19	CUSTOM INSULATOR PAD	16,46	3
20	JOINT BAR INSULATOR	N8J-HD	32
21^	FROG CLAMP (S.M.S.G)	8018	2

GO TRANSIT REFERENCES

PLAN #	TITLE
GTS-0001-REV1	GEOMETRY FOR NO.8 TURNOUTS
GTS-0008-REV1	NO.8 TURNOUT -115 LB RAIL-16'-6" SAMSON POINT SWITCH, UNIFORM RISER DESIGN WOOD TIES
GTS-1125	GUARD RAILS TEE RAIL DESIGN WITH PLANED FLARES AND FLAT PLATES

VOESTALPINE NORTRAK REFERENCES

PLAN #	TITLE
D10154	NO.8- 115LB RAILBOUND MANGANESE FROG

WESTERN CULLEN HAYES REFERENCES

7ST235R-19-20	SWITCH POINT GUARD FOR CHANNEL TIE RIGHT HAND
7ST235L-19-20	SWITCH POINT GUARD FOR CHANNEL TIE LEFT HAND

FROG CLAMP (AFC) & RAIL BRACE (ARB) LOCATION FOR GUARD RAILS

TIE NUMBER	37	38	39	40	41	42	43	44	45
THROUGH RAIL	AFC	ARB	AFC	AFC	ARB	AFC	ARB	ARB	AFC
TURNOUT RAIL	AFC	ARB	AFC	AFC	ARB	AFC	ARB	ARB	AFC

LEGEND

- * WELDED TO TIE DURING MANUFACTURING
- # INSTALLED ON TIE DURING MANUFACTURING
- ^ TO BE INSTALLED ON SWITCH POINT PROTECTOR