



Innovation & Information Technology (I&IT) Telecommunication and Systems Standard

MX-IIT-STD-001

Revision 01

Date: June 2023

Innovation & Information Technology (I&IT) Telecommunication and Systems Standard

MX-IIT-STD-001

Publication Date: September 2020

Revision 01: June 2023

COPYRIGHT © 2020

Metrolinx,

an Agency of the Government of Ontario

The contents of this publication may be used solely as required for services performed on behalf of Metrolinx or for and during preparing a response to a Metrolinx procurement request. Otherwise, this publication or any part thereof shall not be reproduced, re-distributed, stored in an electronic database or transmitted in any form by any means, electronic, photocopying or otherwise, without written permission of the copyright holder. In no event shall this publication or any part thereof be sold or used for commercial purposes.

The information contained herein or otherwise provided or made available ancillary hereto is provided "as is" without warranty or guarantee of any kind as to accuracy, completeness, fitness for use, purpose, non-infringement of third party rights or any other warranty, express or implied. Metrolinx is not responsible and has no liability for any damages, losses, expenses or claims arising or purporting to arise from use of or reliance on the information contained herein.

Preface

This is the fourth edition of the Innovation & Information Technology (I&IT) Telecommunication and Systems Standard. It replaces the Business Technology (BT) Telecommunication and Systems Standard document.

This update includes the name change from Business Technology to I&IT throughout the document, and updates the close circuit TV camera (CCTV) models in Appendix 'A'.

This document defines the Metrolinx I&IT requirements related to both newbuild and retrofitted facilities including specification standards for telecommunications rooms, cabling, and telecommunications racks. This document also defines the Metrolinx I&IT requirements for systems that need to be installed and commissioned as part of new construction or retrofit projects. These specifications are related to systems including close circuit TV camera (CCTV), public announcements (PA), two-way communication (Intercom), Fare Devices and Wi-Fi.

The Innovation & Information Technology (I&IT) Telecommunication and Systems Standards is available for external users to download via the Metrolinx public download site at http://www.gosite.ca/engineering_public/

Suggestions for revision or improvements can be sent to Metrolinx I&IT, Attention: Director of I&IT Product Delivery who shall introduce the proposed changes to Metrolinx I&IT. The Director of I&IT Product Delivery ultimately authorizes the changes. A description of the proposed change shall be included along with information on the background of the application and any other useful rationale or justification. Proposals for revisions or improvements shall also include your name, company affiliation (if applicable), e-mail address, and phone number.

June 2023

Contents

Section	Page
Preface	ii
1. Scope	1
1.1 Overview	1
1.2 Purpose	1
2. Definitions, interpretation and reference documents	2
2.1 Definitions	2
2.2 Abbreviations	5
2.3 Interpretation	8
2.4 Codes, standards and reference documents	8
2.5 Standards Deviation Process	10
3. General	10
3.1 Communications Specialist	10
3.2 Systems installation readiness verification, commissioning, handover and acceptance	10
3.3 Protection of existing communications infrastructure	10
3.4 Communications Cabling Installer	10
3.5 Site clean-up for systems installation	11
4. Office Building	12
4.1 Telecommunications Rooms	12
4.2 Main Telecommunications Room	12
4.3 Riser Telecommunications Room	12
4.4 Cubicle cabling	13
4.5 Inter-communications room cabling	13
4.6 Office Building data riser	13
5. Telecommunications Rooms	14
5.1 Locating Telecommunications Rooms	14
5.2 Co-location within GO Facilities	14

5.3	Station Telecommunications Room	15
5.4	Parking garage Telecommunications Room.....	15
5.5	Office spaces in operational GO Facilities	15
5.6	Platform network concept	16
5.7	Power requirements	16
5.8	Telecommunications Room interconnectivity	16
5.9	Telecommunications Room racks.....	17
6.	Cabling	25
6.1	General	25
6.2	Fibre cabling	26
6.3	Copper cabling.....	30
7.	Systems descriptions and details	35
7.1	CCTV System	35
7.2	Station telephony	40
7.3	Public announcement system	41
7.4	Digital Signage.....	49
7.5	Two-Way communication system	53
7.6	Fare Systems (Devices)	57
7.7	Station Attendant’s System.....	59
7.8	Cellular distributed Antennae system	62
7.9	Enterprise Wi-Fi	64
7.10	Network (digital) clocks	68
7.11	Time keeping / punch clocks.	69
7.12	Building automation systems.....	69
7.13	Building UPS telecommunications	70
7.14	Fuel management systems.....	70
7.15	Access control.....	72
7.16	Office board room audio visual systems.....	73
A.	Appendix A	75

A.1	NEMA enclosures	75
A.2	Closed circuit television.....	77
A.2.1.	CCTV server	77
A.2.2.	Cameras specifications and models.....	77
A.3	Metrolinx enterprise PA system.....	78
A.3.1.	General	78
A.3.2.	PA system power.	80
B.	Appendix B	81
B.1	Systems installation readiness verification	81
B.2	Final cleaning	81
B.3	Commissioning and acceptance.....	81
B.4	Handover testing and documentation.....	81
B.4.1.	Device Data	81
B.4.2.	Fibre cable testing.....	82

Figures

Figure 1: Typical station Main Telecommunications Room rack elevation diagram	18
Figure 2: Typical station and maintenance facility hub room rack elevation diagram	19
Figure 3: Typical station mini hub rack elevation diagram.....	20
Figure 4: Typical GO single-floor office Telecommunications Room rack elevation diagram	21
Figure 5: Typical multi-floor office Main Telecommunications Room rack elevation diagram	22
Figure 6: Typical multi-floor office hub room rack elevation diagram	23
Figure 7: Typical maintenance facility Main Telecommunications Room rack elevation diagram	24
Figure 8: PA system cabling schematic diagram	44
Figure 9: Installation diagram when hub rooms are not present.....	52
Figure 10: Installation diagram when hub rooms are built	52
Figure 11: Typical service counter example	62
Figure 12: Single line fuel management system diagram.....	72
Figure A- 1: NEMA enclosure Diagram	76
Figure A- 2: NEMA enclosure Diagram	76
Figure A- 3: General CCTV diagram	77
Figure A- 4: High level PA architecture	78

Tables

Table 1: List of definitions.....	2
Table 2: List of abbreviations	5
Table 3: GO Facility specific rack requirements	15
Table 4: Fibre performance specifications	27
Table 5: Color coding jack.....	33
Table 6: Color coding patch cables.....	33
Table 7: Rugged (specialty) phones	41
Table 8: Intercom model types.....	56
Table 9: Fare Device power ratings.....	58
Table A- 1: Network zone specifications	77
Table A- 2: CCTV specification.....	77
Table A- 3: Camera model types.....	78
Table A- 4: Access Point and Antenna specifications	80

1. Scope

1.1 Overview

- 1.1.1 A holistic approach to information technology telecommunications and systems shall be followed when constructing at all GO Facilities and Office Buildings. This standard sets out the Metrolinx I&IT requirements for these information technology telecommunications facilities and systems.
- 1.1.2 Compliance with the following Metrolinx I&IT requirements when designing and constructing for new and retrofit projects at GO Facilities and Office Buildings shall ensure the needs of all customers, GO Facility staff and Office Building staff are satisfied following commissioning for information technology telecommunication facilities and systems being placed in-service.

1.2 Purpose

- 1.2.1 The key objective of this standard is to maintain customer experience and satisfaction at GO Facilities as well as Metrolinx staff satisfaction in Office Buildings through a holistic approach to information technology telecommunication and systems by establishing specification requirements that are current, and forward looking, to ensure construction projects have recent technology when they are commissioned.
- 1.2.2 The Contracted Party shall perform all Work in accordance with the requirements of this standard to provide seamless integration within GO Facilities and Office Buildings to maintain satisfaction for customers as well as facility users and operators for systems being placed in-service.

2. Definitions, interpretation, and reference documents

2.1 Definitions

2.1.1 Capitalized terms used in this standard shall have the meanings prescribed in Table 1.

Table 1: List of definitions

Term	Definition
"Accessibility for Ontarians with Disabilities Act" or "AODA"	Means the <i>Accessibility for Ontarians with Disabilities Act, 2005, S.O. 2005, c. 11</i> , as amended or replaced from time to time.
"Acoustics Specialist"	Has the meaning given in Section 7.3.3.1.
"Acoustics Study"	Has the meaning given in Section 7.3.3.2.
"Antenna" or "Antennae"	Means the element used in a wireless device or system to transmit and receive radio signals. Antennas come in many forms and sizes and can be omnidirectional, sector/semi directional, or highly directional.
"Access Point" or "AP"	Means a hardware device or wireless adaptor that functions as a communication hub allowing wireless devices to interconnect.
"Access Point Name" or "APN"	Means the gateway between a mobile network's 'carrier' and another computer network, frequently the public Internet. A mobile device making a data connection must be configured with an APN to present to the carrier.
"Business Days"	Means the days between and including Monday through Friday, and do not include public holidays and weekends. The application of Business days shall be by project location or as stipulated in contract documents.
"CCTV Installation List"	Has the meaning given in Section 7.1.17.
"Communications Cabling Installer"	Has the meaning given in Section 3.4.
"Communications Specialist"	Has the meaning given in Section 3.1.
"Contracted Party"	Means the party responsible for the performance of the Work of the project assignment and under contract or agreement with Metrolinx (e.g. Contractor, Designer, Design-Builder, Project Co, Technical Advisor, or Developer).

Term	Definition
"Device Data Dictionary"	Has the meaning given in Appendix B.
"Digital Signage"	Means remotely managed and individually addressed electronic displays for the communication of digital content for various uses including traveler information, wayfinding, advertising, etc. to targeted audiences.
"Electrical Systems"	Means individually or collectively, the electrical and communications systems including devices, equipment, conductor pathways, structured cabling and power for Fare Devices, CCTV, PA, telephone, network, Digital Signage, Wi-Fi, distributed antenna, security, life-safety and two-way communication system.
"Existing Systems"	Means existing devices, equipment, conductor pathways, structured cabling and power for existing Electrical Systems.
"Fare Devices"	Means the fare collection and purchasing system equipment and network connections used by GO Transit.
"Fare System"	Means the fare collection and purchasing system equipment and network connections used by GO Transit as described in Section 7.6.1.1.
"Fibre Cable Testing Report"	Has the meaning given in Appendix B.
"GO Facility" or "GO Facilities"	Means all GO Transit facilities including rail stations, bus terminals, GO Transit carpool or park and ride lots, UP Express stations, and rail and bus maintenance facilities.
"Good Industry Practice"	Means using standards, practices, methods and procedures to a good commercial and safety standard, conforming to applicable law and exercising that degree of skill and care, diligence, prudence and foresight which would reasonably and ordinarily be expected from a qualified, skilled and experienced person engaged in a similar type of undertaking under the same or similar circumstances.
"HDBaseT"	Consumer electronic and commercial connectivity standard for transmission of uncompressed high-definition video, audio, power, home networking.
"Main Telecommunications Room"	Means the primary telecommunications equipment room for the facilities operation. This is also the room where all external connections (circuits and or trunking) are located. Each of the

Term	Definition
	Telecommunications rooms has their backbone cabling fed back to the Main Telecommunications room. This room is commonly referred to as "Main Communications Room" in other Metrolinx Standards.
"Metrolinx"	Means Metrolinx, a non-share capital corporation continued under the <i>Metrolinx Act</i> , S.O. 2006, c.16 and a Crown Agency in accordance with the <i>Crown Agency Act</i> , R.S.O. 1990, c.48 and includes all operating divisions.
"Metrolinx I&IT"	Means the Metrolinx Innovation & Information Technology department.
"Metrolinx Corporate Security"	Means the division within Metrolinx that is accountable for corporate security.
"Metrolinx Safety"	Means the division within Metrolinx that is accountable for Metrolinx system safety and occupational health and safety.
"Metrolinx Standards"	Means standards developed by Metrolinx as defined in Section 2.4.1h).
"Metrolinx Station Operations"	Means the division within Metrolinx that is accountable for the performance of maintenance services for GO stations.
"Network Time Protocol" or "NTP"	Means the networking protocol for clock synchronization between computer systems over packet-switched, variable-latency data networks. NTP is intended to synchronize all participating computers to within a few milliseconds of UTC.
"Office Building"	Means all GO Transit office buildings that are non-public e.g. 97 Front Street, 20 Bay Street, Milton Station Operations West.
"Ontario Building Code" or "OBC"	Means <i>Ontario Regulation 332/12 (Building Code)</i> made under the <i>Building Code Act, 1992</i> , as amended from time to time.
"Ontario Electrical Safety Code" or "OESC"	Means the <i>Ontario Regulation 164/99: Electrical Safety Code</i> under <i>Electricity Act, 1998</i> , S.O. 1998, C.15, Sched. A, as amended or replaced from time to time.
"PA Coverage Field Study"	Has the meaning given in Section 7.3.3.4.
"PA System Installer"	Has the meaning given in Section 7.3.1.3.
"Pre-Deployment Wi-Fi Site Survey"	Has the meaning given in Section 7.9.1.5.
"Post Installation Wi-Fi"	Has the meaning given in Section 7.9.1.6.

Term	Definition
Site Survey"	
"RF Study "	Has the meaning given in Section 7.9.1.3.
"Standard Deviation Process"	Means the process of this name available on the Metrolinx website: http://www.gosite.ca/engineering_public/ .
"Station Attendant's System"	Has the meaning given in Section 7.7.1.1.
"Telecommunications Room(s)"	Means room(s) housing Metrolinx communications equipment and is a dedicated area where the horizontal cabling is terminated for every floor. Floors may contain multiple Telecommunications rooms depending on building size and requirements. This room is commonly referred to as "Communications Room" in other Metrolinx Standards.
"Wi-Fi Site Survey"	Has the meaning given in Section 7.9.1.4.

2.2 Abbreviations

2.2.1 The abbreviations used in this standard shall have the meaning prescribed in Table 2.

Table 2: List of abbreviations

Abbreviation	Definition
A/C	Means "alternating current"
AIO	Means "all-in-one computer"
AFFL	Means "above finished floor level"
AFILS	Means "audio frequency induction loop system"
ANS	Means "ambient noise sensor"
ANSI	Means "American National Standards Institute"
APC	Means "American Power Conversion"
AV	Means "audio visual"
AWG	Means "American wire gauge"
BICSI	Means "Building Industry Consulting Service International"
BLE	Means "Bluetooth low energy"
BAS	Means "building automation systems"
CCTV	Means "closed circuit television"
C.E.T.	Means "certified engineering technologist"
CSA	Means "Canadian Standards Association"
DAS	Means "distributed antennae system"

Abbreviation	Definition
dB	Means "decibel"
dBA	Means "decibel, A-weighted"
Demarc	Means "demarcation"
DIN	Means "Deutsches Institut fur Normung"
DTE	Means "data terminal equipment"
DTMF	Means "dual tone multi frequency"
DVA	Means "digital voice announcement"
EASE	Means "Electro Acoustic Simulation for Engineers?"
EIA	Means "Electronics Industry Alliance rack"
ENT	Means "electrical non-metallic tubing"
ESA	Means "Electrical Safety Authority"
FAP	Means "fibre adapter panel"
FMVD	Means "fare media vending machine"
GFCI	Means "ground fault circuit receptacle"
GPS	Means "global positioning system"
HA	Means "high availability"
HDPE	Means "high density polyethylene"
HVAC	Means "heating, ventilation, and air conditioning"
Hz	Means "Hertz"
IEC	Means "International Electrotechnical Commission"
IEEE	Means "Institute of Electrical and Electronics Engineers"
iLO	Means "integrated lights-out"
Intercom	Means "two-way communication system"
IP	Means "internet protocol"
IT	Means "information technology"
KVM	Means "keyboard, video and mouse"
LAN	Means "local area network"
LC	Means "lucent connector".
LCD	Means "liquid crystal display"
MDI	Means "media dependent interface"
MFP	Means "multi-function network printer"
MMF	Means "multimode fibre"
NAC	Means "network audio controller"
NAR	Means "network audio router"
NCS	Means "network cabling systems"
NEMA	Means "National Electrical Manufacturers Association"
NNTP	Means "network time protocol"
NOC	Means "network operation center"
NPT	Means "national pipe thread"

Abbreviation	Definition
NVR	Network Video Recorder
ODTR	Means "optical time-domain reflectometer"
OFSTP	Means "optical fiber fystem test procedure"
OM	Means "optical multimode"
OS2	Means "optical single mode fibre category"
PA	Means "public address"
PBX	Private branch exchange is a telephone system within an enterprise that switches calls between enterprise users on local lines while allowing all users to share a certain number of external phone lines.
PC	Means "personal computer"
PDU	Means "power distribution unit"
P.Eng.	Means "professional engineer"
PE	Means "polyethylene"
PoE	Means "power over ethernet"
PSAP	Means "public safety answering point"
PSTN	Means "public switch telephone network"
PTZ	Means "pan tilt zoom control"
QoS	Means "quality of service"
RCDD	Means "Registered Communications Distribution Designer"
RMS	Means "root mean square"
RU	Means "rack unit"
SCADA	Means "supervisory control and data acquisition"
SCOM	Means "System Center Operations Manager"
SFTP	Means "station fare transaction processor"
SIP	Means "session initiation protocol"
SMF	Means "single mode fibre"
SMNP	Means "simple management network protocol"
SPL	Means "sound pressure level"
SPOS	Means "station point of sale"
STIPa	Means "speech transmission index for public address"
TIA	Means "Telecommunications Industry Association"
TIA TSB	Means "Telecommunications Industry Association Technical Service Bulletin"
TSSA	Means "Technical Standards and Safety Authority"
UHF/VHF	Means "ultra-high frequency / very high frequency"
ULC	Means "Underwriter's Laboratory of Canada"
UPS	Means "uninterrupted power supply"
UTC	Means "Coordinated Universal Time"

Abbreviation	Definition
UTP	Means "unshielded twisted pair copper cable"
VLAN	Means "virtual local area network"
VOIP	Means "voice over internet protocol"
WAN	Means "wide area network"
WAP	Means "wireless Access Point"

2.3 Interpretation

2.3.1 This standard shall be interpreted according to the following provisions, unless the context requires a different meaning:

- a) unless the context specifically states otherwise, all obligations included herein are the responsibility of the Contracted Party to undertake;
- b) wherever used herein the plural includes the singular, the singular includes the plural, and each of the masculine, feminine and neutral genders include all other genders;
- c) references to persons shall include their successors and permitted assigns. References to a public organization shall include their successors and assigns, and if a public organization ceases to exist or ceases to perform its functions without a successor or assign, references to such public organization shall be deemed to include a reference to any public organization or any organization or entity which has taken over either or both the functions and responsibilities of such public organization; and
- d) references containing terms such as "includes" and "including", whether or not used with the words "without limitation" or "but not limited to", shall not be deemed limited by the specific enumeration of items but shall, in all cases, be deemed to be without limitation and construed and interpreted to mean "includes without limitation" and "including without limitation".

2.4 Codes, standards and reference documents

2.4.1 All systems, equipment and materials required for Work relating to this standard, shall be provided in accordance with the most current edition of applicable federal, provincial, municipal, and industry codes, standards, and guidelines including the following:

- a) *Accessibility for Ontarians with Disabilities Act (Ontario)*;
- b) Canada Radio-Television and Telecommunications Commission (CRTC);
- c) Canadian Standards Association Group standards including:
 - 1) CAN/CSA-ISO/IEC TR 24704:06 "Customer Premises Cabling for Wireless Access Points";

- d) Electrical Safety Authority;
- e) Institute of Electrical and Electronics Engineers standards including:
 - 1) IEEE 802.3 "Carrier Sense Multiple Access with Collision Detection (CSMA/CD) Access Method: Physical Layer Specifications - Data Terminal Equipment (DTE) Power Via Media Dependent Interface (MDI)";
- f) International Electrotechnical Commission standards including:
 - 1) IEC 60603-7-7 electrical and mechanical specifications;
- g) Session Initiation Protocol Work Group standard "RFC3261: Session Initiation Protocol (SIP)";
- h) All Metrolinx/GO Transit standards (the "Metrolinx Standards"), including:
 - 1) all GO Facility documents on the GO Site (http://www.gosite.ca/engineering_public/); and
 - 2) "GO Transit CCTV and AV Policy (CA-0405-10)" prepared by Metrolinx System Safety, Safety and Security, April 2015;
- i) National Building Code of Canada;
- j) National Fire Code and Fire Commissioner Canada Requirements;
- k) National Fire Protection Association standards;
- l) *Ontario Electrical Safety Code*;
- m) *Ontario Building Code*;
- n) *Ontario Building Code Regulations*;
- o) *Ontario Fire Code*;
- p) Telecommunications Industry Association standards:
 - 1) TIA TSB-162 "Telecommunications Cabling Guidelines for Wireless Access Points";
 - 2) TIA-526 "Standards Test Procedures for Fiber Optic Systems"; and
 - 3) ANSI/TIA 568 series; and
- q) The Fiber Optic Association standard "Optical Fiber System Test Procedure";
- r) Underwriters Laboratory of Canada standards including:
 - 1) ULC CAN-S115 "Standard Method of Fire Tests of Firestop Systems".

2.5 Standards Deviation Process

All permanent and temporary systems shall be designed and constructed to the same specification, quantity and quality outlined in Metrolinx Standards, unless requirements are otherwise outlined in this standard; or a deviation is approved by Metrolinx through the Standard Deviation Process.

3. General

3.1 Communications Specialist

3.1.1 The Contracted Party shall assign a communications specialist (the "Communications Specialist") to monitor the construction of telecommunications and electronic systems. The Communications Specialist shall be an RCDD qualified and shall be either:

- a) a licensed P.Eng. in the Province of Ontario or;
- b) have a C.E.T. certification.

3.1.2 The communications specialist shall be experienced in the design and construction of building services and shall be able to carry out construction supervision in an efficient and professional manner in accordance with Good Industry Practice.

3.2 Systems installation readiness verification, commissioning, handover and acceptance

3.2.1 System installation readiness verification, commissioning, handover and acceptance shall be completed in accordance with the requirements of Appendix B.

3.3 Protection of existing communications infrastructure

3.3.1 Existing communications infrastructure at GO Facilities and Office Buildings shall be protected in accordance with the requirements of Metrolinx Temporary Construction and Customer Requirements for GO Facilities.

3.4 Communications Cabling Installer

3.4.1 The Contracted Party shall ensure that the communications cabling installer resource provided (the "Communications Cabling Installer") is experienced in their trade. The Communications Cabling Installer shall have five years of relevant experience and qualifications shall include:

- a) licensed electrician with communications or electronics specialization; or
- b) licensed electrician with BICSI registration at "Installer Level".

3.5 Site clean-up for systems installation

- 3.5.1 Prior to system installations, the Telecommunications Room shall be cleaned. The Telecommunications Room shall be dust free, damp mopped with HVAC system operational including new filters.
- 3.5.2 Upon completion of the cleaning and preparation of systems installations, Telecommunications Room must be kept in a clean and tidy fashion. Daily inspection and cleaning is required to protect the equipment during installation. This includes vacuuming for dust and debris at the end of each work day to maintain air circulation filtration to ensure dust is not circulated, and general cleanliness of the area including removal of packaging materials, and cable debris.
- 3.5.3 Telecommunications Room spaces shall not to be used for tool or other storage during the systems installation nor shall these spaces be used for machining or work other than systems installation. This includes threading pipes, bending conduits, general fitting of any other material.
- 3.5.4 The Contracted Party shall ensure all cleaning of systems equipment is carried out by a qualified technician with experience and knowledge cleaning data centre environments.

4. Office Building

4.1 Telecommunications Rooms

4.1.1 Each multi-floor Office Building shall be equipped with a minimum of one Telecommunications Room per floor and one Main Telecommunications Room to house the primary systems for the office building and core network infrastructure.

4.1.2 The Telecommunications Rooms on subsequent floors shall be used for aggregation of network cable terminations and network equipment for the associated floor. A backbone cabling system shall be used to connect these rooms to the Main Telecommunication Room and the carrier services in accordance with Section 4.5.

4.2 Main Telecommunications Room

4.2.1 Main Telecommunications Rooms shall be located on the main/above grade floor of Office Buildings to allow for incoming carrier services. Where the first floor is not occupied by Metrolinx, the Main Telecommunications Room shall be located on the lowest floor above finished grade. The choice of the floor may be influenced by the overall longevity of the Office Building:

- a) the Main Telecommunications Room shall house the local cable distribution for the floor it is located on;
- b) carrier services from the facility entry point shall be extended to the Main Telecommunications Room in accordance with Section 4.5; and
- c) the Main Telecommunications Room requires space allocation in accordance with Metrolinx Standards.

4.3 Riser Telecommunications Room

4.3.1 Each floor shall host a riser Telecommunications Room or a local cabling distribution room for data access. These rooms shall be located in accordance with the following requirements:

- a) Telecommunications Room(s) shall be located strategically where cable lengths are minimized, and do not exceed 90 m in total cable length to any endpoint in the Office Building:
 - 1) where a single Telecommunications Room cannot achieve the 90 m total cable length requirement, additional rooms are required to ensure 90 m limit for ethernet cable runs are not exceeded;
- b) Telecommunications Room(s) shall be located directly above each other (stacked) to limit backbone cable distribution length; and
- c) a minimum of two 4" cores with conduits shall be provided between the Telecommunications Room(s).

4.4 Cubicle cabling

4.4.1 Cubicle cabling shall be in accordance with Section 6 and the following requirements:

- a) each cubical shall be provisioned with a minimum of one data outlet per user;
- b) all cables shall be terminated in the cubicle furniture above the tabletop;
- c) all cables shall be installed and integrated in accordance with the furniture manufacturer's specifications; and
- d) all cables shall be single cable home runs to the nearest Telecommunications Room without splices, or patching within the furniture, or Office Building.

4.5 Inter-communications room cabling

4.5.1 A data and voice backbone is required to interconnect the Office Building with the Metrolinx wide area network, and all telecommunications rooms in an Office Building. For greater clarity, the Demarc room refers to the Metrolinx agreed Demarc room.

4.5.2 All office facilities shall be provisioned with the Demarc and carrier services. The Contracted Party shall coordinate the installation of the carrier Demarc services in the Main Telecommunication Room. Where the carrier's point of presence is not on the same floor, or within the Main Telecommunication Room, an extension of the Demarc services is required and shall be provided by the Contracted Party and included in the design documents.

4.5.3 Where the Demarc is not in the Main Telecommunication Room it shall be in a Telecommunications Room accepted by Metrolinx that is secured and meets the requirements of this Section 4.

4.5.4 Each Office Building shall have a minimum of 24 strand single mode fibre Demarc conforming to the carrier's specifications for fibre Demarcs.

4.5.5 Each Office Building shall have a minimum of 50 copper pair.

4.5.6 Metrolinx I&IT is responsible for the provisioning of data and voice services with the carrier directly and shall provide this information to the Contracted Party.

4.6 Office Building data riser

4.6.1 Fibre services shall be set from the Main Telecommunications Room to each of the Telecommunications Room(s) in an Office Building, with the minimum of 24 strands of SMF OS2 in accordance with Section 6. 25 pair copper connectivity shall also be installed.

5. Telecommunications Rooms

5.1 Locating Telecommunications Rooms

- 5.1.1 Each GO Facility shall have a minimum of one Main Telecommunications Room to house the primary systems at the facility and core network infrastructure.
- 5.1.2 The cable length for end devices shall be no longer than 90 m. At all locations where new construction or significant changes are made to the size or footprint of the GO Facility, a determination shall be carried out to ensure Telecommunications Room(s) are strategically located within 90 m cable length to all device locations.
- 5.1.3 The location of the Main Telecommunications Room and the Telecommunications Room(s) of all sizes shall be included in the design plans and submitted to Metrolinx for review.

5.2 Co-location within GO Facilities

- 5.2.1 In situations where co-location of telecommunications spaces is required or proposed, coordination between the relevant parties shall be performed. Factors determining co-location between parties include current working agreements between parties, sensitivity of equipment intended to be co-located and the physical space issues. In situations where co-location is approved by Metrolinx, all Metrolinx cabinets shall be locked at all times. Space for future cages or complete fire partitioning shall be installed based on the agreements between organizations.
- 5.2.2 Colocation shall only be considered if shared with other telecommunications equipment in accordance with Metrolinx Standards. Sharing this space with other parties or purposes, including janitorial, storage or others, shall not be permitted. A physical barrier, such as a Block wall or poured concrete on all sides shall be installed, with only one entry door for access control.
- 5.2.3 In cases where co-location is not permitted, or used, and parties are to use separate Telecommunications Rooms, each room shall share a single wall. At Metrolinx request accommodation for interconnectivity of these rooms shall be provided with a single common overhead tray between rooms.
- 5.2.4 All Telecommunications Room(s) shall be sized based on the requirements of this document and the requirements of Metrolinx Standards.
- 5.2.5 The Telecommunications Rooms shall only house systems outlined within this document. Any systems which are not described in this document including fire annunciation panels, fuel management systems, SCADA, and others are not permitted to be housed in the Telecommunications Rooms unless the following conditions are satisfied:
- a) written approval has been provided by Metrolinx; and

- b) the room size must be increased to accommodate these systems without impacting space for Metrolinx equipment.

5.3 Station Telecommunications Room

5.3.1 Each station (rail or bus) shall have a Telecommunications Room within the station building in accordance with Metrolinx Standards. This room shall be sized meeting the needs of the GO Facility in accordance with Metrolinx Standards.

5.4 Parking garage Telecommunications Room

5.4.1 A Telecommunications Room is required in all parking garages. This room may become the "Main" Telecommunications Room for the facility, or a sub-Telecommunications Room based on current and planned site conditions. In either case these rooms shall meet the requirements for primary Telecommunications Rooms in parking garages in accordance with Metrolinx Standards. These spaces shall allow for a minimum of six full height racks to be installed with the required clearances in accordance with Metrolinx Standards.

5.4.2 Subsequent rooms shall be strategically placed to allow reach of all devices within a 90 m cable distance. Location preference shall be given to areas of high passenger flow. For example, closer to elevator lobbies, egress areas to pedestrian bridges and other locations where passengers may congregate. These areas will have a higher concentration of network devices.

5.4.3 These rooms shall be placed in vertical alignment where possible to allow for a straight cable path between rooms for backbone cabling. A detailed drawing showing room interconnectivity and routing shall be submitted to Metrolinx for review during design.

5.5 Office spaces in operational GO Facilities

5.5.1 In office spaces which have a concentration of employees or large open warehouse type facilities, the need for sub-Telecommunications Rooms is increased.

5.5.2 There shall be no location within a branch facility or office that is not within 90 m of a Telecommunications Room.

5.5.3 GO Facilities shall have a primary Telecommunications Room, located next to the electrical room on the ground floor, in accordance with Metrolinx Standards. Different GO Facility types shall have varying minimum Telecommunications Room sizes, in accordance with Table 3.

Table 3: GO Facility specific rack requirements

GO Facility type	Space required
Class A Bus and Rail Maintenance Facilities	6 Racks
Class B Bus Facilities	5 Racks
Class C Bus Facilities	4 Racks

5.6 Platform network concept

- 5.6.1 Mini hub rooms shall be provided in accordance with Metrolinx Standards and as shown in Figure 3 along rail platforms to ensure that every end-device is within the 90 m ethernet copper cable limitation.

5.7 Power requirements

- 5.7.1 Each rack shall include two APC AP8830 power distribution units. These shall be installed in accordance with the manufacturer's instructions and secured within the rear section of the rack. The Contracted Party shall ensure these racks are connected to the NEMA L5-20R outlets on the overhead tray.

5.8 Telecommunications Room interconnectivity

- 5.8.1 At station facilities with multiple Telecommunications Room(s), the following interconnectivity is required:
- a) conduit requirements:
 - 1) all new Telecommunications Room(s) within a GO Facility shall have conduits for telecommunications systems in accordance with Metrolinx Standards. These conduits are for the following systems:
 - (A) network fibre (CCTV, IP network, Digital Signage, VOIP telephony, access control and security);
 - (B) telephone backbone;
 - (C) PA;
 - (D) Fare Systems (Presto);
 - (E) Chubb security; and
 - (F) spares.
 - b) carrier Demarc requirements:
 - 1) each GO Facility requires a Bell Demarc point for telecommunications. Station facilities and rail layover facilities require a minimum of a 50 pair Bell copper Demarc, and a 24 strand single mode fibre Demarc point. These Demarcs shall be terminated in the Main Telecommunication Room on to the Demarc point. Any office space, bus maintenance facility (excluding Class C Bus Storage Facilities), or rail maintenance facilities require a 100 pair copper Demarc and a fibre Demarc point;
 - 2) all circuits for telecommunications will be ordered by Metrolinx I&IT. At least three months' notice prior to intended opening of a new GO Facility or reopening on an existing

GO Facility shall be given to Metrolinx for coordination of these circuits and to ensure service is available for operations;

- 3) the electrical site plan design drawing shall clearly identify the location of the Bell duct banks and Demarc locations in accordance with Metrolinx Standards;
- 4) the Contracted Party shall be responsible for coordinating the Demarc point with Bell Canada; and
- 5) in cases where relocation of the Bell Demarc service is required, the Demarc shall be duplicated in both locations to allow Metrolinx I&IT the flexibility in migrating each individual circuit from one Demarc point to the other.

5.9 Telecommunications Room racks

5.9.1 The following specification for telecommunication racks applies to all Telecommunications Rooms (in the office spaces, stations and maintenance facilities). Quantity of racks shall be provided in accordance with Table 3 and in accordance with Metrolinx Standards.

5.9.2 The telecommunications racks shall be Panduit N8222BC series or equivalent approved by Metrolinx in accordance with the following requirements:

- a) overall dimensions 78.8"H x 31.5"W x 48.0"D (2000 mm H x 800 mm W x 1200 mm D);
- b) dual hinge perforated front door opens to the left or right;
- c) 70% perforated vented locking front door;
- d) 79% vented locking rear doors;
- e) locking, removable side panels;
- f) CTGN3X5 Cool boot used to seal off 3" x 5" cabinet top openings when cables are routed through the top of a cabinet one per each opening required;
- g) two sets of cage nut equipment mounting rails;
- h) 42 RU cable management on front and rear of front posts;
- i) two sets of SN25F fingers or equivalent; and
- j) rack construction method shall ensure an electrically bonded structure for ease of grounding.

5.9.3 The telecommunications racks shall be installed in accordance with the following general requirements:

- a) grounded to the Telecommunications Room grounding bus-bar;
- b) adjacent Metrolinx cabinet shall be ganged (bolted) together for stability;

- c) fastened directly to the floor; and
- d) in accordance with the following typical telecommunication rack elevation diagrams in Figure 1 through to Figure 7.

Figure 1: Typical station Main Telecommunications Room rack elevation diagram

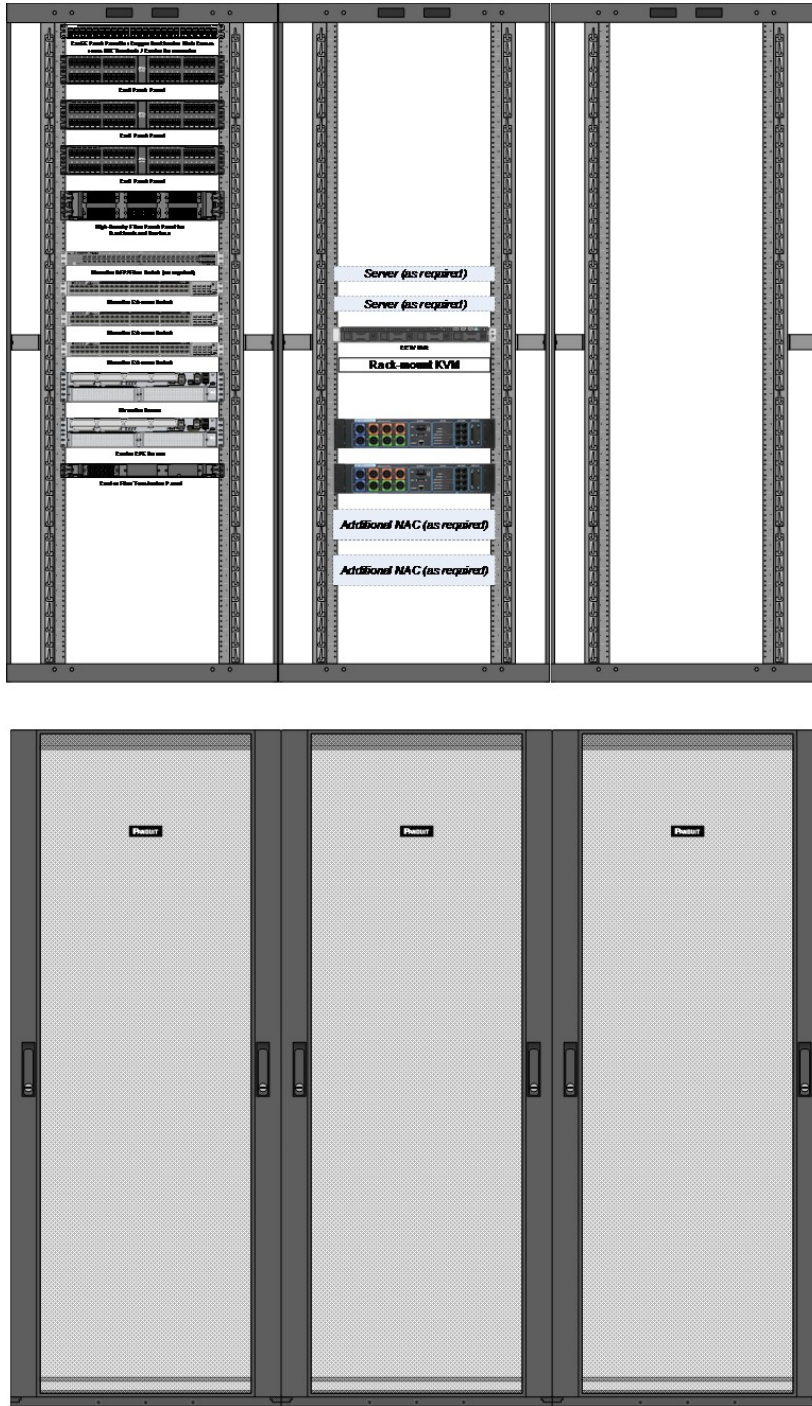

Figure 2: Typical station and maintenance facility hub room rack elevation diagram

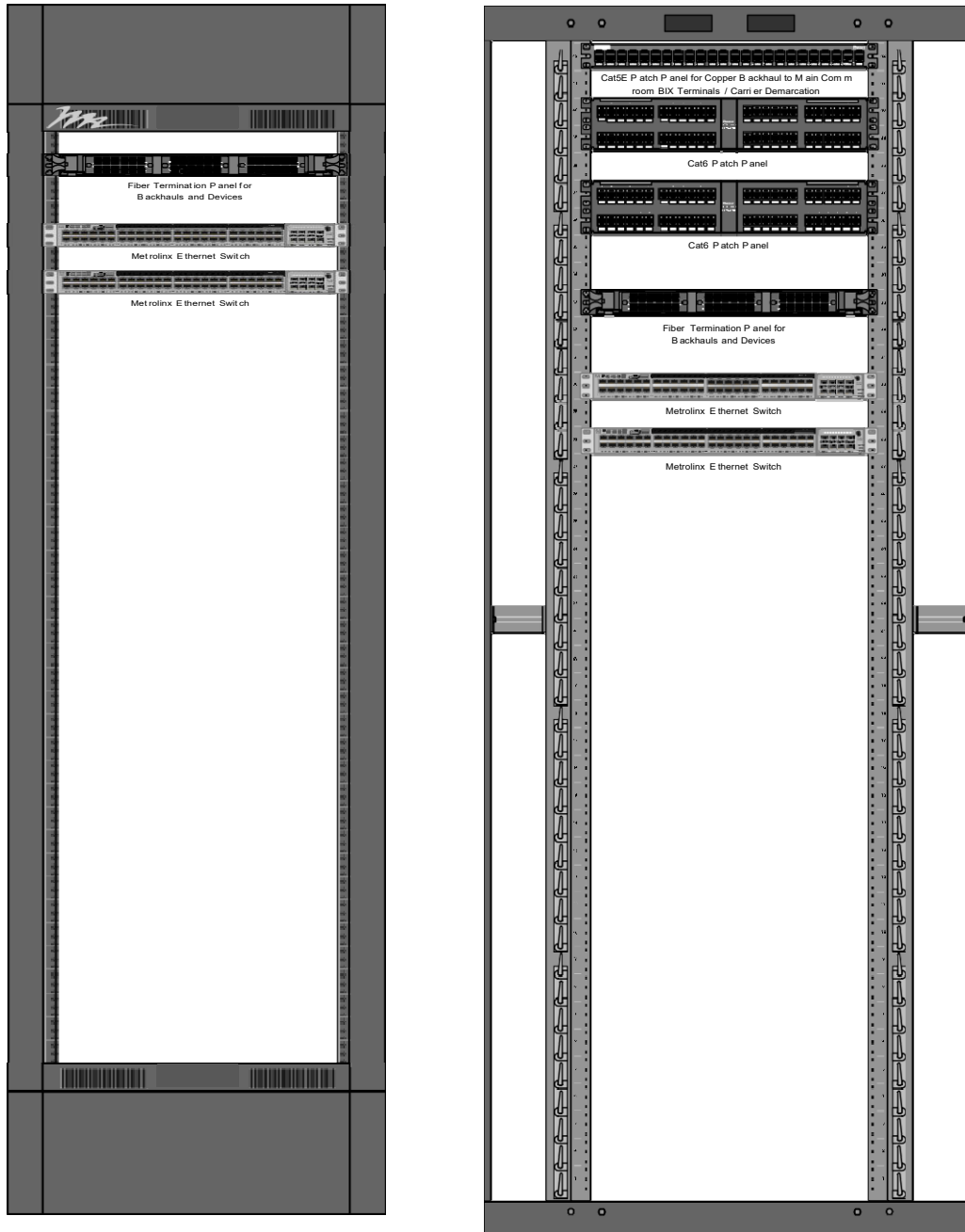

Figure 3: Typical station mini hub rack elevation diagram



Figure 4: Typical GO single-floor office Telecommunications Room rack elevation diagram

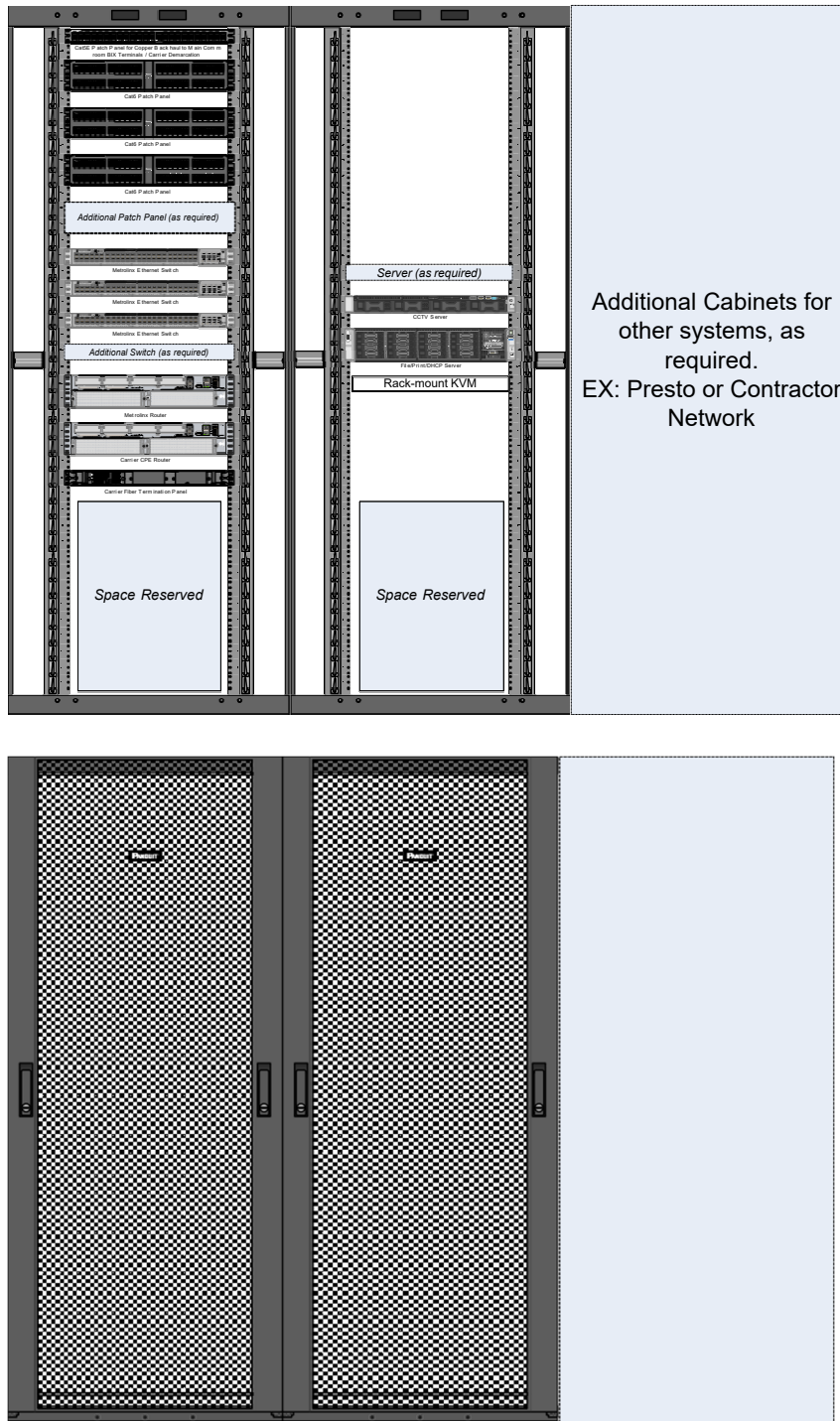

Figure 5: Typical multi-floor office Main Telecommunications Room rack elevation diagram

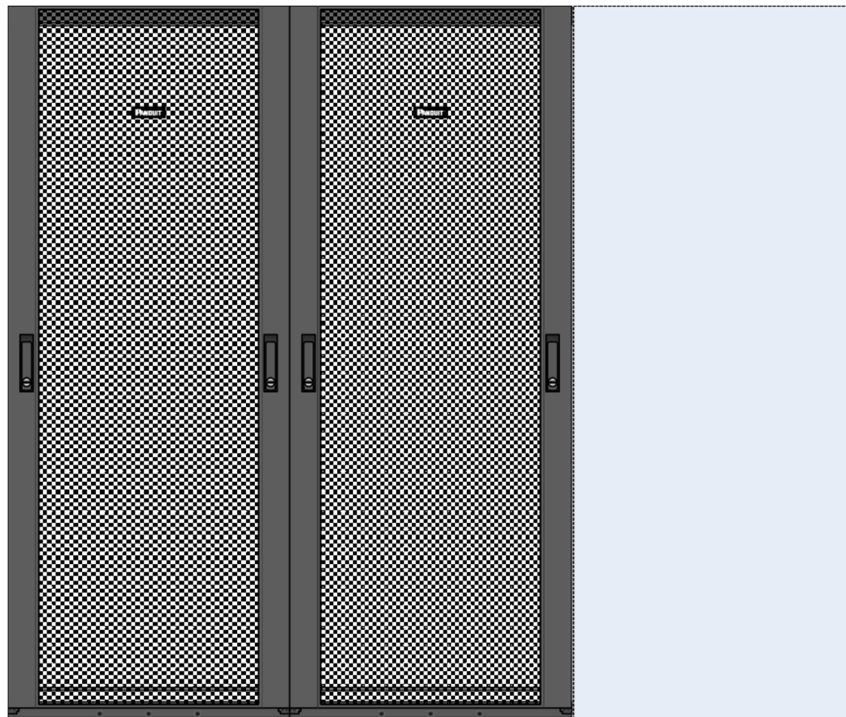
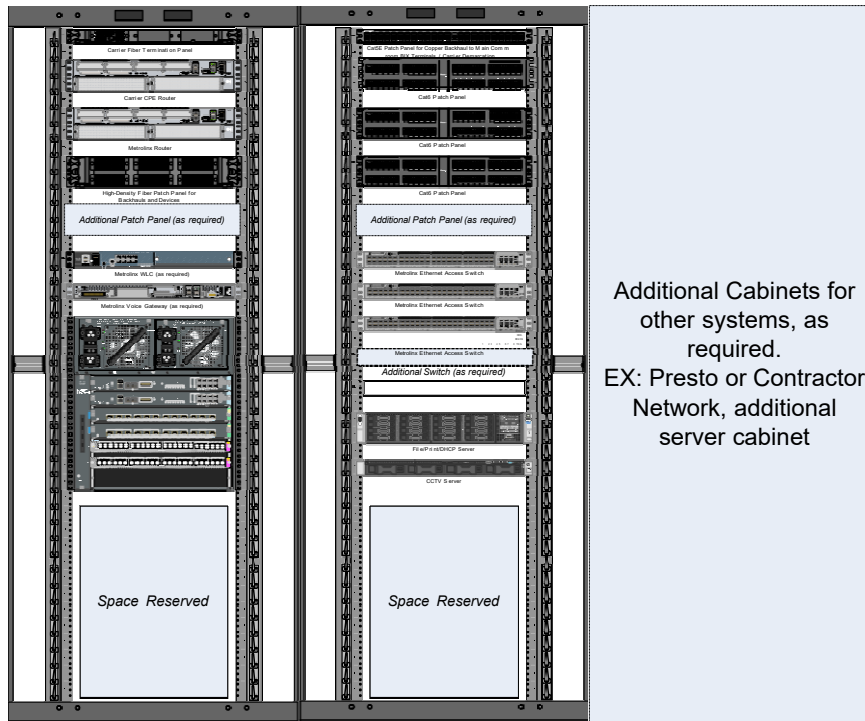

Figure 6: Typical multi-floor office hub room rack elevation diagram

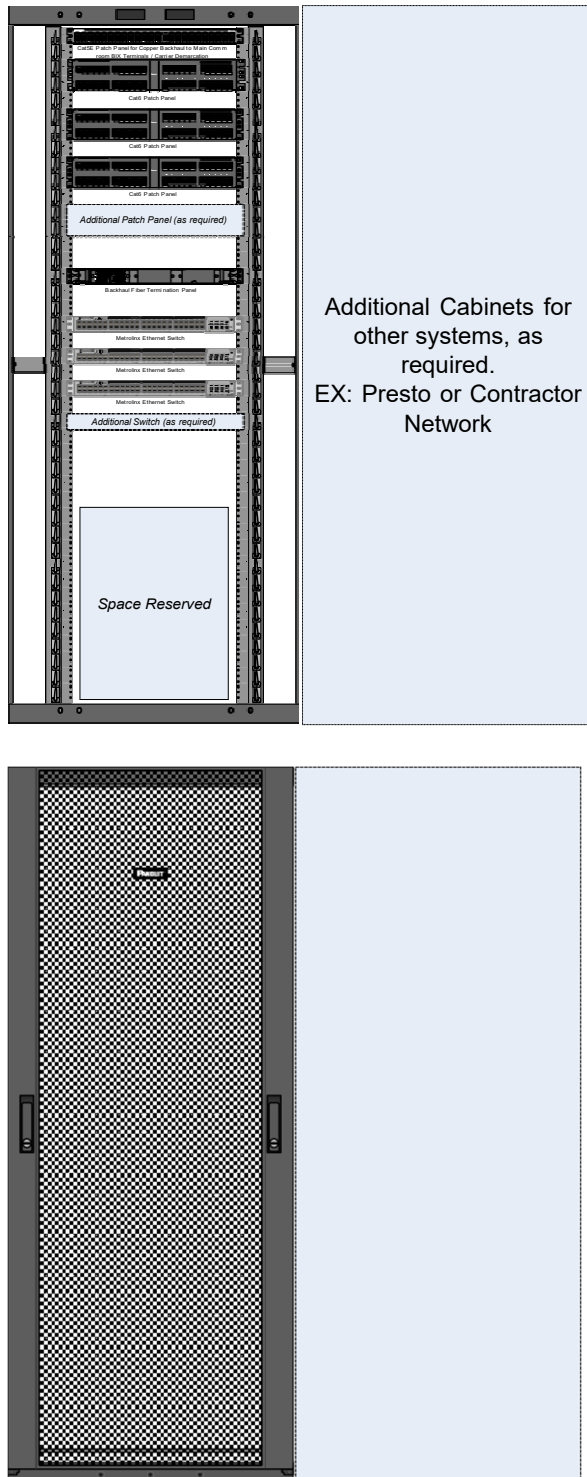
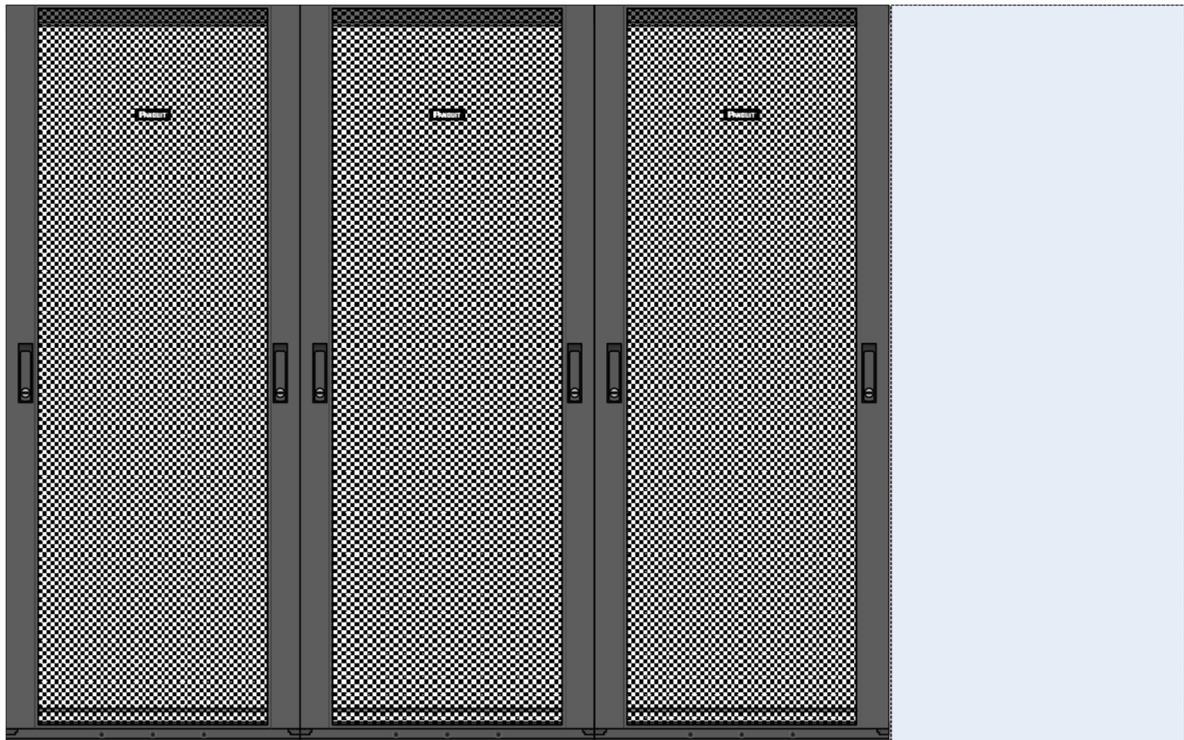
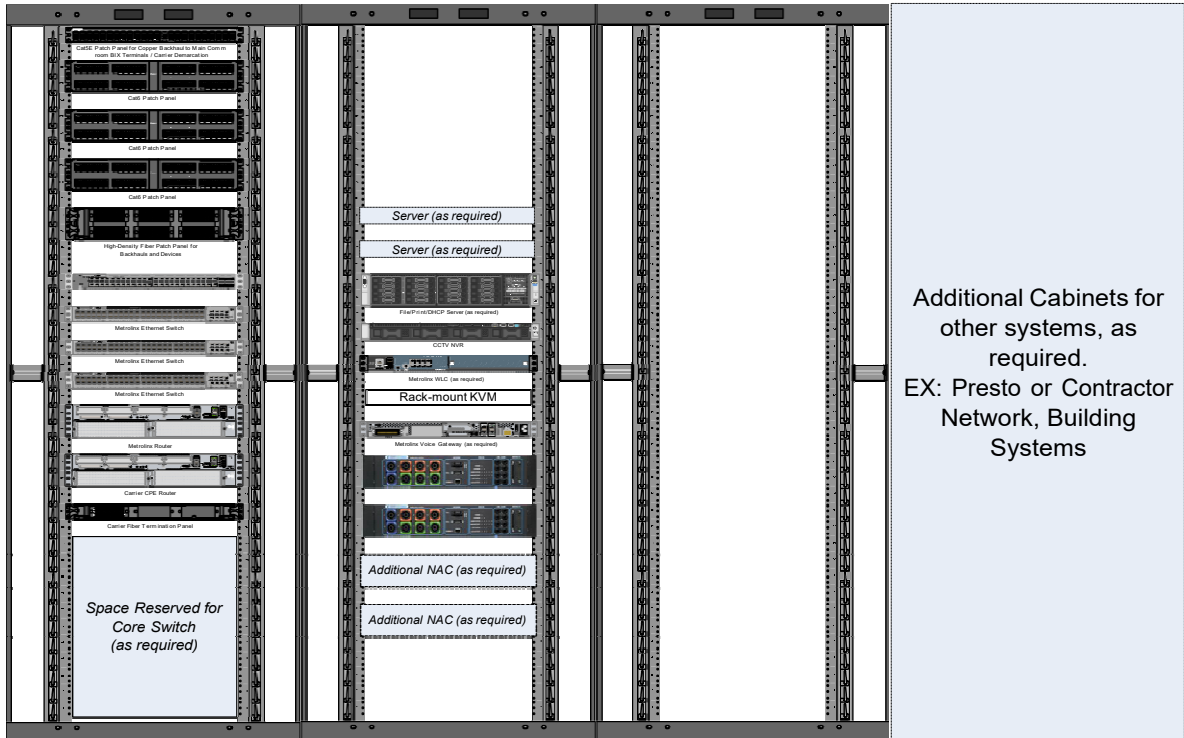

Figure 7: Typical maintenance facility Main Telecommunications Room rack elevation diagram



6. Cabling

6.1 General

- 6.1.1 The technical features of the network cabling system shall include Category 5E cabling, Category 6, Category 6A copper cabling, OS2 single mode and OM3, OM4 and OM5 multi mode fibre optic cable installation, to support facilities with new and existing fibre installations.
- 6.1.2 Cables shall be installed in the physical star configuration with separate horizontal and backbone sub-systems.
- 6.1.3 Horizontal cables shall link work areas to Telecommunications Room located on same floor. Telecommunications Room(s) shall be linked to the Main Telecommunications Room by backbone cable systems.
- 6.1.4 NCS shall comprise several interdependent cable subsystems extending from the outlet at the workstation to the owners main incoming communications Demarc point. NCS shall be defined, designed and installed as an end-to-end system.
- 6.1.5 NCS components shall be provided by a single manufacturer.
- 6.1.6 The Contracted Party shall ensure the NCS is installed by the manufacturer's certified NCS contractor and shall provide a 25-year system warranty/certification on all copper and fiber links and/or channels.
- 6.1.7 The Contracted Party shall provide all equipment, materials, labor and services to complete the NCS for voice and data applications generally as shown on the drawing and in accordance with the requirements of this document.
- 6.1.8 The cabling system shall be applications-independent and network technology neutral.
- 6.1.9 OS2 9/125-micron single mode fibre optics shall be used for distribution cabling.
- 6.1.10 Patch panels shall be used for termination of UTP copper and fibre optic cables.
- 6.1.11 Category 6 UTP and Category 6A UTP cables on frames shall be terminated with the following hardware:
- a) termination frames including all required anchoring hardware and brackets to attach frames together; and
 - b) mounts, distribution rings and grounding hardware required to fully populate all frames shall compliment the termination frames.
- 6.1.12 All racks, cabinets and wall mount enclosures shall be grounded and bonded.
- 6.1.13 Network cabling installation shall be provisioned for the deployment of a wireless infrastructure in accordance with the guidance in CAN/CSA-ISO/IEC TR 24704:06 and TIA TSB-162.

- 6.1.14 Cabling plan that supplies PoE shall be wired in accordance with the guidance in IEEE standard 802.3.
- 6.1.15 The cabling installations shall use the following media:
- a) 100 ohm twisted pair cable (in accordance with ANSI/TIA 568 series) of Category 6 and above;
 - b) single mode optical fibre cable (in accordance with ANSI/TIA 568 series) single mode cable in all new installations; and
 - c) multi-mode optical fibre (in accordance with ANSI/TIA 568 series) used only in existing multi-mode installations, to service an EXISTING multi-mode device.
- 6.1.16 All cabling shall be terminated in accordance with ANSI/TIA 568 series. All applicable configuration parameters and connecting hardware in accordance with IEC 60603-7-7 , unless specifically noted otherwise.
- 6.1.17 All cabling shall be bundled using Tak-Ty, velcro tie-wraps.

6.2 Fibre cabling

- 6.2.1 All cabling between Telecommunications Room(s), between buildings and along roadway or rail corridors is considered to be 'back-bone' cabling. Size, type and number of strands / pairs shall be identified in design plans for each location and submitted to Metrolinx for review during design.
- 6.2.2 Fibre backbone cabling
- 6.2.2.1 All fibre back-bone cabling shall be a dedicated fibre cable between the Main Telecommunications Room and the sub-Telecommunications Room or other locations. The minimum number of strands of a backbone cable shall be no less than 24 strands. Each Telecommunications Room shall be connected with a 24 strand fibre.
- 6.2.2.2 Where cables are linking multiple buildings together, or is an outdoor type cable, the cable shall be single mode fibre regardless of link distance.
- 6.2.3 Telecommunications Room fibre protection
- 6.2.3.1 All fibre cabling within the Telecommunications Room shall be enclosed in orange corrugated flexible HDPE type conduit. Each end of the conduit shall terminate:
- a) directly on the wall mount termination enclosure; and
 - b) on the fibre enclosure within the network rack.
- 6.2.3.2 The overhead tray shall be utilized for the fibre cable installation in accordance with the following:
- a) the flexible conduit shall be secured to the tray at a minimum of 1.0 m intervals using Tak-Ty, velcro type ties; and

- b) the ties shall not crush or deflect the flexible conduit in any way.

6.2.4 Horizontal fibre cabling

6.2.4.1 Horizontal fibre cabling shall be used for all field terminated fibre devices where a fibre transceiver or other end device is to be installed. This includes ticket vending machines, Digital Signage, IP Cameras, Wireless APs and other devices which are beyond 90 m cable length from the nearest Telecommunications Room. The field end of these cables is to be terminated with LC type connectors.

6.2.4.2 All horizontal fibre cabling shall be terminated on the Telecommunications Room backboard (wall) using LC type connectors and extended to the network rack fibre patch panel. All strands terminated on the backboard shall be extended to the patch panel. All rack patch panel terminations shall be of LC type connectors.

6.2.4.3 All cables installed shall be fully terminated at both ends unless otherwise specified.

6.2.4.4 All cables shall be labeled in accordance with Metrolinx Standards and shall include an additional cable label affixed to the T-Bar structure of the suspended ceiling located as close to the location of the cable termination. This label must be visible and legible from the floor and be white in background with black text.

6.2.5 Fibre cable

6.2.5.1 All locations which require outdoor fibre between Telecommunications Room(s) shall use single mode outdoor rated cable in accordance with Table 4. Outdoor rated cable shall also be used where the permanent link length between Telecommunications Rooms exceeds 500 m:

- a) installed cable shall be 9/125 micron core/cladding, OS2 single-mode, and graded index glass fibre. All materials in the cable shall be dielectric. Metrolinx I&IT must accept the fibre type before installation; and
- b) single mode performance: installed fibre must meet or exceed the performance specifications specified in Table 4.

Table 4: Fibre performance specifications

Fibre cable types	Wavelength (nm)	Max. Attn. (dB/Km)
SMF, Inside (OS1)	1,310	0.75
	1,550	0.75
SMF, Outside (OS2)	1,310	0.34
	1,550	0.22

6.2.6 Indoor cable

6.2.6.1 Riser cable shall be used for all interior installations and shall meet the following requirements:

- a) incorporate tight buffered 900 um, mechanical strippable Teflon;

- b) support EIA/TIA -568 color coding for fibre optic cable;
- c) have aramid yarn strength member, capable of supporting a short-term tensile load of 400 lb. without stretching;
- d) capable of bend radii as small as 20 x outside cable diameter (under installation load) and 10 x outside cable diameter (long term load); and
- e) capable of a minimum crush resistance of 850 lb./in.

6.2.7 Outdoor cable

6.2.7.1 Outdoor cable shall be used for all exterior installations and shall meet the following requirements:

- a) outdoor cable shall be used for all applications where cable is to be run in underground conduits or duct banks; and
- b) outdoor cable is not permitted for interior applications. Outdoor cable shall meet the following specifications:
 - 1) buffer tube, 250 um, acrylate;
 - 2) EIA/TIA -568 color coding for fibre optic cable;
 - 3) flooded core;
 - 4) capable of bend radii as small as 20 x outside cable diameter (under installation load) and 10 x outside cable diameter (long term load); and
 - 5) capable of a minimum crush resistance of 850 lb./in.

6.2.7.2 All outdoor fibre must be installed in conduits. Direct buried cable is not permitted.

Note: *Multi mode fibre is no longer supported by Metrolinx Standards.*

6.2.8 Fibre patch cable

6.2.8.1 All fibre patch cables shall be Panduit Opti-Core® 10 GIG 50/125 or 9/125 or equivalent accepted by Metrolinx.

6.2.8.2 All patch cables shall be accepted by Metrolinx and shall conform to industry standard color identification for single, multi, and 10 GbE cable requirements.

6.2.8.3 All GO Facilities and Office Buildings where fibre patch panels are installed within rack enclosures shall conform to the following requirements:

- a) use Panduit Model FRME2U or equivalent accepted by Metrolinx;
- b) mount to standard 19 " or 23 " EIA rack or cabinet;
- c) hold QuickNet™ or Opticom® Fibre Adapter Panels (FAPs) and Opticom® Fibre Optic Splice Modules;

- d) accessed at front and rear via durable molded-hinge doors at all models;
- e) have an integral bend radius control and cable management for fibre patch cords;
- f) have multiple trunk cable entry locations; and
- g) include fibre optic cable routing kit (grommets, cable ties, saddle clips, strain relief bracket, and ID/caution labels) for various cable management solutions.

6.2.9 Fibre termination

- 6.2.9.1 All backbone and field fibre cables shall be terminated within a wall type enclosure. This enclosure shall be sized according to the number of strands being terminated and shall allow for 50% future expansion.
- 6.2.9.2 All strands of each cable shall be terminated on the wall enclosure using LC type connectors.
- 6.2.9.3 A minimum of 3.0 m of slack cable shall be left within the wall termination enclosure.
- 6.2.9.4 All strands shall be extended from the wall enclosure to the network rack enclosure using LC type terminations at the rack patch panel. These shall be enclosed in core flex or other protective flexible ENT conduit orange in colour.
- 6.2.9.5 This conduit shall be terminated at the wall fibre enclosure and within the network rack fibre enclosure patch panel tray.

6.2.10 Fibre patch panel

- 6.2.10.1 All facilities where fibre patch panels are installed within rack enclosures shall comply with the following:
 - a) use Panduit Model FRME2U or equivalent approved by Metrolinx;
 - b) mount to standard 19 " or 23 " EIA rack or cabinet;
 - c) hold QuickNet™ or Opticom® Fibre Adapter Panels (FAPs) and Opticom® Fibre Optic Splice Modules;
 - d) front and rear access on all models shall be via durable moulded-hinge doors;
 - e) integral bend radius control and cable management for fibre patch cords shall be provided; and
 - f) multiple trunk cable entry locations shall include fibre optic cable routing kit (grommets, cable ties, saddle clips, strain relief bracket, and ID/caution labels) for various cable management solutions.

6.2.11 Fibre cable installation and testing

6.2.11.1 Prior to installation, it is required that each strand of fibre in a cable shall be tested with an OTDR for length and transmission anomalies while on the reel.

6.2.11.2 After installation and termination handover testing and documentation shall be completed in accordance with Appendix B.

6.3 Copper cabling

6.3.1 Copper backbone cabling

6.3.1.1 Copper cable shall be used only for communications with network cabling where more than four pairs are required and shall not to be used for runs to the desk or end devices.

6.3.1.2 Category 5E Telephone Backbone cable shall to be used for backbones with a minimum of 25 pairs required between all Telecommunications Room(s).

6.3.2 Copper horizontal cabling

6.3.2.1 Cable to the desk or cubicle:

- a) a minimum of two Category 6 or Category 6A data cables in blue color supporting both voice and data shall be provided for each desk;
- b) each Service Counter shall have a minimum of eight Category 6 or Category 6A data/voice outlets, terminated using Category-6 or Category 6A RJ45 outlets Shuttered jacks; and
- c) all cable outlets in the service counter shall be mounted in a patch panel type frame, mounted below the millwork.

6.3.2.2 The patch panels in the service counter shall be Panduit CWPP12WBL or equivalent Panduit part: CJH688TGBU or CJH6X88TGBU. The patch panels in the service counter shall have the following features:

- a) incorporate the release snap feature on faceplate allowing simple front access for termination and accessibility to installed modules;
- b) accept Modules for UTP, fibre optic, and audio/video, which snap in and out for easy moves, adds, and changes;
- c) mount directly onto wall or millwork surfaces;
- d) support modular design for easy cabling revisions;
- e) be no more than 9.5" x 2.5" x 1.75" in size;
- f) the cables connecting the ticket booths shall have direct home run to the nearest Telecommunications Room on a 19 inch rack, terminated on the flat RJ45 patch panel; and
- g) the mountable panel shall use Panduit CPP24WBLY or CPP48WBLY modular patch panel.

- 6.3.2.3 All horizontal cable terminations located in suspended ceilings, or similar areas must adhere to the following conditions:
- a) terminate on surface mount jack module affixed to above permanent structure (i.e. mounted to underside of open steel web joist, concrete ceiling or similar);
 - b) terminations shall not be affixed to other mechanical systems such as piping, HVAC, plumbing etc.;
 - c) conform to horizontal Category 6 or Category 6A standard cabling specifications in accordance with IEEE 802.3;
 - d) labeled in accordance with Metrolinx Standards; and
 - e) include an additional cable label affixed to the T-Bar structure of the suspended ceiling located as close to the location of the cable termination. This label must be visible and legible from the floor and be white in background with black text.
- 6.3.3 Copper cabling to outdoor field devices
- 6.3.3.1 Outdoor devices requiring ethernet or IP connectivity shall use an outdoor rated NEMA 4X enclosure / junction box with Panduit Z22C-6/SMPL.
- 6.3.3.2 A minimum of two cables shall be run and terminated in the outdoor junction boxes. The junction boxes shall accommodate up to six cables.
- 6.3.3.3 The junction boxes / enclosures shall be mounted within six metres from the end devices, with the suitable patch cable run from the junction box to the end device at the time of installation.
- 6.3.3.4 Outdoor junction boxes shall be sized large enough to accept up to three field conduits and the permanent link conduit to the Telecommunications Room.
- 6.3.3.5 Field cable and the permanent link cable shall use category 6 or 6A OSP Panduit part # PUO6C04BL-U, PFO6X04BL-CEG or equivalent cable meeting the ANSI/TIA 568 series and all applicable IEC 61156-5 Category 6 or category 6A component standards. The conduits shall be used in duct and conduit installations only and shall not be used in aerial or direct burial applications.
- 6.3.3.6 Field cable / permanent link cable shall have a gel-filled construction, using 23 AWG construction with polyolefin insulation.
- 6.3.3.7 The copper conductors shall use twisted in pairs, separated by a pair separator and covered with an ultraviolet-resistant and abrasion-resistant polyethylene jacket.
- 6.3.4 Category 5E backbone cable
- 6.3.4.1 All legacy PSTN voice with runs greater than four pairs shall use Category 5E plenum type cable.

6.3.4.2 All cables installed in or passing through unconditioned spaces shall be of buried service quality.

6.3.4.3 The Category 5E cables shall conform to the following:

- a) minimum of 25 pair cables shall be installed unless otherwise stated;
- b) use 24 AWG bare copper wire insulated with FEP 9 (plenum);
- c) support 10 Base-T, 100 Base-TX, 1000 Base-T and be verified to TIA/EIA 568 Category 5E backbone cable power performance;
- d) withstand a maximum installation tension of 25 LB;
- e) have a minimum bend radius of 175 mm;
- f) be terminated at both ends onto Northern Telecom BIX Punch down terminal strip or equivalent, unless otherwise stated; and
- g) terminal strips shall be installed between 48" and 84" above the finished floor.

6.3.5 Horizontal Category 6/6A cable

6.3.5.1 All horizontal data cables shall use Category 6 or 6A Panduit part # PUP6C04BU-F, PUP6AV04BU-G or equivalent approved by Metrolinx.

6.3.5.2 All cables installed shall be fully terminated at both ends unless otherwise specified.

6.3.5.3 Patch panel terminations shall meet the TIA/EIA T568A Category 6 or Category 6A cable installation standards.

6.3.5.4 End devices shall be fully terminated to T568A standards on modular wall face plates or surface mount boxes, as specified by Metrolinx.

6.3.5.5 Where cables need to be terminated with a male end such as for inside and SPOS, installer shall use field terminable RJ45 Plug Panduit FP6X88MTG or equivalent for modified single connector permanent link.

6.3.5.6 All cable runs shall conform to TIA/EIA Category 6 or Category 6A installation specifications and guidelines.

6.3.5.7 Cable bundles shall not exceed more than 25 cables and shall be secured with Tak-Ty velcro type cable ties.

6.3.5.8 All cables shall be secured to dedicated communication raceways and with Tak-Ty velcro type cable ties.

6.3.6 Wall jacks

6.3.6.1 Wall jacks shall be colored as specified in Table 5.

Table 5: Color coding jack

Use	Colour
Data / Corporate Network	Blue
Telephone	Blue
Radio Data / Communication	Orange

6.3.7 Patch cables

6.3.7.1 All patch cables provided shall be Panduit TX6 Plus Category 6 and 6A cables.

6.3.7.2 Cable lengths shall be appropriately bundled and of reasonable length allowing for proper cable routing needed for a tidy and organized installation in accordance with Metrolinx Standards.

6.3.7.3 Patch cables shall be colored as specified in Table 6.

Table 6: Color coding patch cables

Use	Colour
Data / corporate network PC / printers / telephone sets	Blue
Corporate Servers	Red
Switch / Router Crossovers and Normal	Yellow
iLO / KVM / Management	Purple / Indigo

6.3.7.4 All cables must meet or exceed the criteria set by ULC CAN-S115.

6.3.7.5 Non-permanent CSA approved intumescent fire stopping shall be supplied and installed maintaining a minimum of one-hour rating, to cap all empty sleeves and around cabling passing through sleeves or walls.

6.3.7.6 Following the installation of all cables, all duct entrances into the building shall be sealed with duct sealing compound to prevent ingress of moisture, foreign material and rodents.

6.3.7.7 Exposed cable ends shall be protected from moisture ingress.

6.3.8 Network patch panel (Telecommunications Room)

6.3.8.1 Network patch panels shall be provided as necessary and shall be minimum of 24 port type. Angled patch panels and flat type patch panels shall be provided in accordance with locational requirements.

6.3.8.2 All patch panels at station buildings shall be of flat type. These patch panels shall be installed in accordance with the rack elevation drawings. No new patch panels shall be installed until the previous patch panel has been fully used.

6.3.8.3 The patch panels shall be equivalent to Panduit CPP24FMWBLY and shall have the following features:

- a) rear mounted faceplates shall allow modules to be flush with front of patch panel;
 - b) be accepting of modules for UTP, fibre optic, and audio/video, which snap in and out for easy moves, adds, and changes;
 - c) have pre-printed numbers above each port for easy identification;
 - d) contain white write-on areas for port and/or panel identification;
 - e) mounted to standard EIA 19 " racks or 23 " racks with optional extender brackets;
 - f) minimum 24 spaces available for modules; and
 - g) incorporate the flat patch panel.
- 6.3.8.4 If a patch panel currently exists which is not of this specification, new inserts matching the existing patch panel shall be used. All new subsequent patch panels shall meet the requirements of this document.
- 6.3.9 Office Buildings/ bus or rail maintenance facilities copper patch panels.
- 6.3.9.1 All Office Buildings where a network cable rack is installed shall use the angular type patch panels of the same brand and model of the existing patch panels on site. No new patch panels shall be installed until the previous patch panel has been fully used.
- 6.3.9.2 These patch panels shall be Panduit CPPLA48WBLY or an equivalent accepted by Metrolinx and shall have the following features:
- a) rear mounted faceplates allow modules to be flush with front of patch panel;
 - b) be accepting of modules for UTP, fibre optic, and audio/video, which snap in and out for easy moves, adds, and changes;
 - c) have pre-printed numbers above each port for easy identification;
 - d) contain white write-on areas for port and/or panel identification;
 - e) mounted to standard EIA 19 " racks or 23 " racks with optional extender brackets;
 - f) minimum 48 spaces available for modules; and
 - g) incorporate the angular patch panel.

7. Systems descriptions and details

7.1 CCTV System

7.1.1 General

7.1.1.1 CCTV systems shall be provided to remotely monitor and assess areas identified either as secure, public, or controlled access at stations, terminals, and other locations to monitor train, bus arrivals, and departures, observe customer flow, and to conduct surveillance and investigation through recorded and live capabilities that are related to the protection of its corporate assets.

7.1.1.2 The level of CCTV system design and installation at each station or facility is dependent upon the conditions of each site, providing safety and security for Metrolinx customers and employees. Metrolinx shall determine the monitoring and recording requirements.

7.1.1.3 Each Metrolinx location includes the following components as a minimum:

- a) CCTV head end system;
- b) cameras—fixed or pan/tilt/zoom;
- c) camera housings—weatherproof;
- d) lenses—fixed with auto-iris;
- e) cable systems (copper wire and fibre optic);
- f) transmission architecture; and
- g) recording archive system.

Note: See *Metrolinx Standards for list of required locations and placement for CCTV Cameras in new designs.*

7.1.1.4 Each head end system shall include the following hardware:

- a) rack console;
- b) switch gear;
- c) NVR server;
- d) recording software; and
- e) monitoring PC.

7.1.1.5 All cameras shall be IP based with the exception of existing legacy cameras. Net new installations shall use IP cameras.

7.1.1.6 IP based CCTV cameras shall be able to integrate with Metrolinx enterprise CCTV system (IndigoVision Control Centre) without adapters, additional software or appliances.

- 7.1.1.7 IP based CCTV cameras shall have a web based interface for initial setup and configuration of cameras.
- 7.1.2 Copper Category 6 cameras
- 7.1.2.1 All cameras shall be located within 90 m of a Metrolinx network point of presence. The accepted method is a Telecommunications Room, Rail Platform Mini Hub Room. Devices beyond the 90m's in remote locations such as parking lots, usage of a NEMA enclosure solution applies.
- 7.1.2.2 Fibre cabling shall:
- a) use single-mode fibre in accordance with the requirements of Section 6;
 - b) be used only when there are no hub rooms within 90 m of the device; and
 - c) be run to the nearest Metrolinx network point of presence, which may be a Telecommunications Room, platform mini hub room or an outdoor NEMA box.
- 7.1.2.3 For rail platform mini hub room or outdoor NEMA box:
- a) the NEMA enclosure shall have proper separation between AC power and data cabling;
 - b) all internal components shall be mounted on DIN rails;
 - c) the enclosure shall be lockable;
 - d) enclosure shall be waterproof;
 - e) power and data components shall be installed in accordance with the OESC; and
 - f) all electrical work shall have ESA inspection and certificate.
- 7.1.2.4 Device conduits shall be in accordance with Metrolinx Standards.
- 7.1.2.5 Device power shall meet the following requirements:
- a) IP based devices shall be powered via PoE where applicable;
 - b) pre-Existing Inside Elevator Analog Camera shall be powered via elevator-based power supply;
 - c) Metrolinx switches are capable of PoE+, any power requirements beyond PoE+ shall be provided by the Contracted Party; and
 - d) the Contracted Party shall be responsible for power budget and shall not exceed 75% of capability of servicing switch.
- 7.1.2.6 Network shall meet the following requirements:

- a) IP connectivity to the Metrolinx network shall be via a Metrolinx switch located in the nearest hub room;
- b) the network infrastructure shall be monitored on both ends to ensure device communications are available, using Cisco Prime, HP OpsBridge and Microsoft SCOM systems and IndigoVision control software; and
- c) IP address assignment and management shall follow Metrolinx Standards. IP schema and individual IP addresses shall be provided by Metrolinx I&IT.

7.1.3 Integration requirements for camera

7.1.3.1 CCTV Cameras shall work in conjunction with access control systems, based on requirements for specific locations.

7.1.4 Access control

7.1.4.1 Access control shall be in accordance with the requirements of GO Transit CCTV and AV Policy (CA-0405-10).

7.1.5 User management

7.1.5.1 User management shall be in accordance with the requirements of GO Transit CCTV and AV Policy (CA-0405-10).

7.1.6 Session management

7.1.6.1 Session management shall be in accordance with the requirements of GO Transit CCTV and AV Policy (CA-0405-10).

7.1.7 Audit, logging, and monitoring

7.1.7.1 Audit, logging and monitoring shall be in accordance with GO Transit CCTV and AV Policy (CA-0405-10).

7.1.8 Other requirements

7.1.8.1 System components shall include the IndigoVision products in order to ensure compatibility with the existing system and be environmentally rated for use.

7.1.8.2 Hardware, software and licenses shall be sourced from IndigoVision or authorized IndigoVision partner.

7.1.8.3 The Contracted Party shall ensure the installation, configuration and programming is completed by an authorized IndigoVision partner.

7.1.9 System installation approach

7.1.9.1 The Contracted Party shall provide all components indicated on the contract drawings such as supports, bollards, conduits, raceways, device boxes, enclosures, cable, wires, connectors, equipment, controls, devices, controllers, camera stations, relays, interfaces, programming and any other components, to ensure the camera system is completely installed and satisfactorily operating.

- 7.1.9.2 The Contracted Party shall provide any other equipment, labor or material necessary to fulfill the functional and performance criteria of the system regardless of being shown in the specification or contract drawings.
- 7.1.9.3 The Contracted Party shall work with Metrolinx I&IT for network connection and configuration.
- 7.1.9.4 The Contracted Party shall work with Metrolinx I&IT to integrate cameras with existing Metrolinx systems.
- 7.1.9.5 The Contracted Party shall work with Metrolinx I&IT to program the camera based on Metrolinx business requirements.
- 7.1.9.6 The Contracted Party shall perform the installation and systems integration work only if factory authorized and trained on the specified products.
- 7.1.9.7 The Contracted Party shall, on request, surrender within five days of asking, a copy of training certificates issued by the manufacturer relating to the products being installed.
- 7.1.9.8 System components shall include IndigoVision products in order to ensure compatibility with existing system.
- 7.1.9.9 Hardware, software and licenses shall be sourced from IndigoVision or authorized IndigoVision partner.
- 7.1.9.10 The Contracted Party shall ensure installation, configuration and programming is completed by an authorized IndigoVision partner.
- 7.1.10 Data/records retention
 - 7.1.10.1 Date/records retention shall be in accordance with Metrolinx Standards.
- 7.1.11 Availability
 - 7.1.11.1 The CCTV system shall be available 24/7, 365 days of the year.
- 7.1.12 Recording software
 - 7.1.12.1 Each NVR shall be configured to record every camera 24 hours per day for duration of five days for stations with the exception of Union Station, which is 30 days, unless otherwise approved by Metrolinx. Retention dates must be approved by Metrolinx I&IT and Metrolinx Corporate Security.
- 7.1.13 Monitoring PC
 - 7.1.13.1 Each site which requires a monitoring PC shall be provided a small form factor desktop PC. These requirements will be provided by Metrolinx I&IT.
 - 7.1.13.2 Each station monitor shall have a screen of 32 " in size. The location of the screen shall be determined by Metrolinx Station Operations. These screens shall be wall mounted and shall include all hardware required for the installation. Requirements for LCD monitors shall be provided by Metrolinx I&IT.

- 7.1.14 Station service counter or other mounted CCTV screen locations
 - 7.1.14.1 Each screen shall be mounted within the ticket booth, where each ticket selling agent may see the screen without strain, or discomfort. In addition, the screens shall be kept in a position that does not allow the public to see the contents of the screen.
 - 7.1.14.2 An approved location shall be agreed upon by Metrolinx Station Operations, Metrolinx I&IT, and Metrolinx Safety.
- 7.1.15 Service counter
 - 7.1.15.1 Each PC shall be installed within close proximity of the ticket selling agents and the monitor in a location agreed upon by Metrolinx Station Operations, Metrolinx I&IT, and Metrolinx Safety and as shown in Figure 11.
 - 7.1.15.2 Each service counter / monitoring PC shall be connected to the network switch in the Telecommunications Room and port designated by Metrolinx.
 - 7.1.15.3 The service counter PC shall be configured with Metrolinx provided user accounts and specifications. This will be provided by Metrolinx at the time of installation.
 - 7.1.15.4 A network outlet and two duplex receptacles are required for the monitoring PC.
- 7.1.16 Camera connectivity and control
 - 7.1.16.1 Each camera connected to the Indigo Vision system must be visible from the corporate network. In coordination with a Metrolinx I&IT representative, each camera will be tested by the Contracted Party for PTZ control and image quality using the Indigo Vision Client Application.
 - 7.1.16.2 The Contracted Party shall provide two weeks' notice to Metrolinx prior to the anticipated completion of the CCTV system to verify and test all cameras. Testing shall be scheduled with Metrolinx I&IT.
- 7.1.17 Reporting connectivity and control:
 - 7.1.17.1 Upon completion of the CCTV installation, a complete list in Excel format shall be submitted to Metrolinx two weeks prior to the connectivity and control test (the "CCTV Installation List"). The CCTV Installation List shall include the following details for each camera:
 - a) make;
 - b) model;
 - c) serial number;
 - d) PTZ protocol settings;
 - e) IP address;
 - f) description of location;
 - g) date of Installation (for warranty purposes); and

- h) GO Facility/Office Building site details (location and address).

7.2 Station telephony

7.2.1 Station phone

7.2.1.1 The station telephone shall provide voice communication capability between the station attendant and other Metrolinx business units. Metrolinx standard station telephony system is based on Cisco VoIP phones located in the ticket booth. The phones are designed and programmed to provide multiple, integrated unique functions for station operations.

7.2.1.2 Category 6 ethernet cables shall be pulled to the service counter cabling jacks. Cable shall conform to the requirements in Section 6. Locations are defined by the service counter requirements in Metrolinx Standards.

7.2.1.3 The VoIP station phone shall include the following functions:

- a) emergency phone – used by Network Operation Center to reach the station;
- b) public announcement – used to make station PA announcements; and
- c) regular calls including 911 (which is handled by the centralized SIP trunk).

7.2.1.4 These phones shall be supplied and installed by Metrolinx.

7.2.2 Pay phones

7.2.2.1 The station pay phone shall provide telephone service to be used by the passengers.

7.2.2.2 This telephone shall be on a regular PSTN circuit and located in a convenient area for passenger access. Each station shall have one internal pay phone and one external pay phone; however, at larger stations the number of pay phones shall be increased as directed by Metrolinx. The telephone is supplied and installed by Bell Canada. The conduit from the Telecommunication Room to the payphones shall be designed by the Contracted Party.

7.2.2.3 At the preliminary design stage, the Contracted Party shall request Metrolinx to provide the number and location of pay phones. Metrolinx will contact Bell Canada to identify the number of pay phones Bell Canada is to provide. Metrolinx Station Operations will select the pay phone locations. The Contracted Party shall ensure that the appropriate sub-trades provide the telecommunications conduit, pay phone footing and power. The footing template will be provided by Metrolinx. Cable and connections shall be provided by Bell Canada.

7.2.3 Rugged (specialty) phones:

7.2.3.1 For specialty phones, select Guardian IP phone series shall be used, as specified in Table 7.

Table 7: Rugged (specialty) phones

Phone type	Model
Waterproof (vehicle wash bays)	WRT-40-V
Outdoors	WTT-40-V
Rugged shop (repair bays, shops)	SCT-40-V
Special purpose (hazardous):	SCR-40-V-H

7.3 Public announcement system

7.3.1 General

7.3.1.1 PA system shall be provided for announcement messages via the Metrolinx enterprise IP network serving as the primary communication link between designated staff, passengers and crew members at rail stations, bus terminals, rail and bus maintenance facilities, depots and offices. The PA system shall provide the ability to communicate accurate and timely information to the target audience.

7.3.1.2 The Contracted Party shall provide a complete and working PA system. The key components of the PA system shall include open access NetSpire™ CXS server (communication exchange server), open access NetSpire™ NAC, zone speakers and input devices, such as operator console microphone, noise cancelling microphone and the telephone input.

7.3.1.3 The Contracted Party shall ensure the portion of installation related to all components outside of the PA system racks are completed by a qualified installer, (the "PA System Installer"). The PA System Installer shall:

- a) be knowledgeable in Metrolinx Standards for PA system requirements;
- b) provide quality workmanship and components in accordance with Metrolinx Standards; and
- c) have a successful proven record of past experience with similar systems of type and scale.

7.3.1.4 The Contracted Party shall ensure a NetSpire™ approved, vendor and installer provides "head end" component purchase, installation and zoning configuration to align with the accepted Acoustics Study. The same vendor shall provide network racks for the PA system and any other Telecommunications Room equipment that is required to have a functioning PA head end. Metrolinx shall connect and configure the head end components for Metrolinx network connectivity.

7.3.1.5 PA system coverage by the speakers shall include platforms, station buildings, waiting areas, tunnels, bus loops and parts of Metrolinx parking garages.

7.3.2 Location

7.3.2.1 NetSpire™ CXS servers shall be installed within Metrolinx Data Centres.

- 7.3.2.2 NetSpire™ CONAC01/6020/USL NAC's shall be installed at PA cabinets within each local Main Telecommunication Room.
- 7.3.2.3 Speakers shall be installed at rail stations, bus terminals, bus garages, rail maintenance facilities and Metrolinx offices.
- 7.3.3 General design approach
- 7.3.3.1 The Contracted Party shall assign a qualified acoustics specialist (the "Acoustics Specialist") to complete a predictive SPL, STIPa and audio coverage study. The Acoustics Specialist shall be:
- a) knowledgeable of the NetSpire™ system; and
 - b) knowledgeable of the Metrolinx Standard requirement for PA Speakers.
- 7.3.3.2 The Contracted Party shall submit to Metrolinx for review the predictive SPL, STIPa and audio coverage study (the "Acoustics Study"). The Acoustics Study shall meet the following requirements:
- a) include calculations and speaker layout details; and
 - b) take into consideration head end hardware, speakers and types, placement, surface finishes, obstructions, and other environmental and structural factors that impact acoustics.
- 7.3.3.3 The Acoustics Study shall be submitted for Metrolinx review and acceptance a minimum of 20 Business Days in advance of 75% Design completion of Metrolinx systems equipment. The Contracted Party shall allow for adjustments to the SPL, STIPa and audio coverage at Metrolinx request.
- 7.3.3.4 A field study shall be conducted to determine the actual SPL, STIPa and audio coverage levels achieved and submitted to Metrolinx for review (the "PA Coverage Field Study") by the PA system installer and the Metrolinx I&IT field specialists. The PA Coverage Field Study shall meet the following requirements:
- a) be completed by the PA system installer in the presence of Metrolinx I&IT field specialists; and
 - b) report on a plan drawing the SPL, STIPa and audio coverage levels achieved on site , as well as the acceptable clarity of speech levels.
- 7.3.3.5 If adjustments are required to the SPL, STIPa and audio coverage , the field study shall be repeated and resubmitted to Metrolinx for review until Metrolinx are satisfied that the SPL and speech clarity levels are in conformance with the requirements.
- 7.3.4 Design requirements
- 7.3.4.1 New PA systems shall be an extension of and shall be fully integrated with existing PA systems.

- 7.3.4.2 The PA system shall facilitate the broadcast of audio announcements in selected zones at Metrolinx facilities, in accordance with the requirements of Section 7.3.6.
- 7.3.5 PA zone design requirements
- 7.3.5.1 The design of the PA Systems zones shall be facility and location specific. It shall take into consideration the location specific Metrolinx business requirements along with surface finishes, obstructions, and any other environmental and structural factors that impact acoustics and wiring.
- 7.3.5.2 The following zones are typical groupings of areas to be included for each rail station facility where applicable:
- a) platforms - shelters and canopies (grouped as one zone);
 - b) bus loops;
 - c) station buildings, staff rooms, vestibules and lobbies;
 - d) tunnels, stairwells, bridges and entrances; and
 - e) passenger pick up/drop-off and waiting areas.
- 7.3.5.3 The PA zones shall comply with the following:
- a) each zone shall comprise of interleaved cabling to allow for amplifier redundancy;
 - b) the interleaving cables shall account for no more than a 50% audible coverage loss of the installed speaker system, whereas the detected faults shall be reported to the NetSpire™ CSX server(s);
 - c) zones shall be connected either locally to the main PA communications cabinet or networked using fibre or copper ethernet connections as required for connection to the remote points;
 - d) where two platforms share an island platform this shall be deemed to be a single acoustic space and shall be treated as one zone; and
 - e) indoor speakers that are part of an outdoor loop shall be appropriately tapped to provide correct sound pressure level for that enclosed space.
- 7.3.6 Loudspeaker circuits design requirements
- 7.3.6.1 Each zone covered by the PA system shall have loudspeakers installed with at least two separate interleaved loudspeaker circuits (i.e. A/B circuits) fed from dedicated NetSpire™ CONAC01/6020/USL Network Audio Controllers, to assure that, in case of a failure at one loudspeaker unit, the 50% of the audio zone shall remain operational.
- 7.3.6.2 Separate NetSpire™ CONAC01/6020/USL NAC shall be used to provide end to end redundancy.
- 7.3.7 Cable routing

- 7.3.7.1 Following the Acoustics Study and installation of the dedicated conduit, the Contracted Party shall install speakers and their wiring in accordance with the following requirements:
- a) PA system shall utilize diverse cabling routes, designated to avoid areas of fire and mechanical damage risk, with cable types selected accordingly;
 - b) all PA system cables shall be terminated in the PA system rack at the field cabling Demarc point using DIN rail mounted blade connectors appropriately sized for field cable conductor gauges. to allow for quick disconnection of the facility cabling;
 - c) each speaker channel shall be connected directly from the field cable Demarc point to the NetSpire™ CONAC01/6020/USL Network Audio Controller and terminated on its own NL4FX connector using pins 2+ and 2-for 70 V operation; and
 - d) PA system cabling shall be in accordance with Figure 8.

Figure 8: PA system cabling schematic diagram

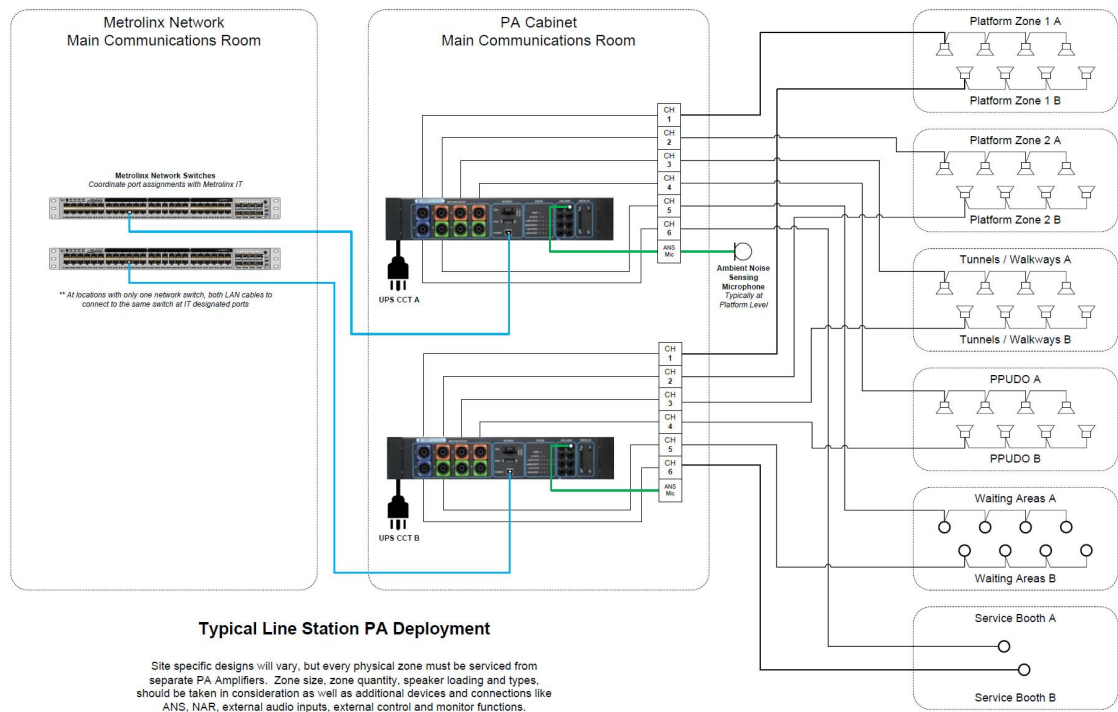

7.3.8 Public announcement speakers

7.3.8.1 Components used in the PA system speakers shall be in accordance with Metrolinx Standards.

7.3.8.2 All speakers in the PA System shall be of 70 V type, and be of adequate construction and quality commensurate with the installation location and have available data files for audio simulation software such as EASE.

- 7.3.8.3 The PA system speakers for the outdoor installations shall comply with the following:
- a) speakers shall be outdoor weatherproof types with a minimum IP rating of IP66;
 - b) speakers shall be resistant to the environment and provide for the direct entry of any connected PA cable, using drip loops; and
 - c) PA cables shall not be exposed and shall be in accordance with Metrolinx Standards.
- 7.3.8.4 The PA system speakers for the outdoor installations shall have the following features:
- a) the speakers shall have line voltage of 70 V and maximum wattage of 15 W RMS continuous; and
 - b) the speakers shall have a full adjustment in both the vertical and horizontal plane.
- 7.3.8.5 The mounting of the PA system speakers for the outdoor installations shall comply with the following:
- a) speakers shall be mounted on lighting poles in such a manner as to eliminate the necessity of drilling the lighting poles (by stainless steel banding) and to provide resistance to vandalism;
 - b) speakers shall use an NPT threaded gland entry with liquid tight cable gland and be coupled to the pole gland plate using liquid tight flexible conduit; and
 - c) the mounting height for speakers on light standards shall be 4.0 m above grade.
- 7.3.8.6 Indoor speakers shall comply with the following:
- a) speakers shall be of surfaces and recessed types; and
 - b) speakers operating temperature range shall be within 0 degrees Celsius to 50 degrees Celsius.
- 7.3.8.7 The PA system speakers for the indoor installations shall have the following features:
- a) speakers shall have the dual cone, treated paper design with a built-in 70 V multi-tap transformer;
 - b) speakers shall support the volume control in waiting areas accessible from the volume controller installed at the ticket attendant booth that shall provide attenuation of 20 dBA at any wattage tap;
 - c) speakers shall have line voltage of 70 V and maximum wattage of 10 W RMS continuous; and

- d) the finish of the speakers shall match location color as required by Metrolinx.
- 7.3.8.8 The mounting of the PA system speakers for indoor installations shall comply with the following:
- a) a steel baffle or suspended ceiling tile support bridge and back box shall be provided for either flush or surface mounting applications to suit the location;
 - b) the speaker's back box shall be supported independently of the grid in a ceiling tile application; and
 - c) speakers in public areas shall be flush mounted or camouflaged whenever possible.
- 7.3.8.9 The speakers installed in the shelters and tunnels shall comply with the following:
- a) speakers shall have a vandal resistant die cast housing complete with stainless steel tamper-resistant "TORX" screws to prevent unauthorized access;
 - b) speakers shall be designed for maximum output at a minimum power loss and shall be installed in accordance with manufacturer's recommendations; and
 - c) speakers shall be suitable for the environment and available tunnel clearance height.
- 7.3.8.10 The PA system speakers for the shelters and tunnels installations shall have the following features:
- a) speakers shall incorporate a sealed back for extra protection and audibility;
 - b) the speaker's grills and housing shall be white in color or finished as required by Metrolinx;
 - c) the operating temperature shall be between -30 degrees Celsius to +50 degrees Celsius; and
 - d) the speakers shall have Line voltage 70 V and maximum wattage 8 W RMS continuous.
- 7.3.8.11 The mounting of the PA system speakers for shelter and tunnel installations shall comply with the following: When used in exposed areas or inside tunnels, a stainless steel speaker-mounting bracket shall be used.
- 7.3.9 Speaker cabling
- 7.3.9.1 All PA wiring located not in the environment controlled areas shall be outdoor/burial rated 14 AWG and installed in conduit.
- 7.3.9.2 All PA wiring located in the environment controlled areas shall be rated 14 AWG and installed in the appropriate conduit in accordance with Metrolinx Standards.

- 7.3.9.3 Splicing of cabling shall be above ground and shall only be done in an approved enclosure in accordance with IEEE 802.3 with access for maintenance.
- 7.3.9.4 When performing the repairs of the cable, the Contracted Party shall replace the damaged section, with the exception of the case when the conduit is crushing the cable and doesn't allow for removal or replacement. The repairs shall be made using gel filled connectors shall be to prevent oxidation of connections and electrical shorts due to water intrusion.
- 7.3.10 Acoustic design requirements
- 7.3.10.1 When placing the speakers in the PA system, the Contracted Party shall comply with the spacing requirements provided by Metrolinx and the PA Coverage Study.
- 7.3.10.2 SPL shall comply with the following:
- a) the PA system shall be designed to provide the required SPL at a height of 1.5 m AFFL;
 - b) the PA shall provide an SPL of 10 dBA above the normal ambient noise levels, with a minimum of 65 dBA;
 - c) the maximum commissioned SPL dBA shall be determined by the environmental requirements and local regulations for noise pollution;
 - d) the system shall be able to provide an SPL of at least 85 dBA. The maximum commissioned SPL (dBA) shall be determined by the environmental requirements and local regulations for noise pollution, and subject to location and number of speakers;
 - e) the system shall have ANS microphones for each platform zone that will automatically adjust the system SPL (within the constraints of the minimum and maximum SPL settings in the system) to compensate for increases in background noise;
 - f) the system intelligibility shall be measured using STIPa. STIPa measurements shall be taken at 1.5 m AFFL at positions halfway between speakers, with a minimum of three measurements taken at each position. Sufficient measurements shall be taken to allow a representative area of the zone under test to be evaluated;
 - g) the PA system shall have a minimum STIPa of 0.5 in all areas, where the reverberation time (RT60) is less than two seconds. Where acoustically difficult areas have been identified at the design stage (RT60 is greater than two seconds) or the acoustic treatment cannot be applied to the area, the acoustic modelling shall be utilized to predict the achievable STIPa performance; and
 - h) the PA system incorporating multiple speakers shall be designed to promote an increased number of smaller speakers, evenly spaced so as to provide appropriate sound pressure levels and increased intelligibility.
- 7.3.10.3 AFILS design shall comply with the following requirements

- a) AFILS cables shall be segregated from all other PA cables;
- b) AFILS shall be installed in all passenger information and gathering and waiting areas as determined by Metrolinx, in line with local disability legislation requirements; and
- c) AFILS design shall comply with the international standard for loop system IEC60118-4, Appendix C.

7.3.11 Public announcement system technical and environmental requirements

7.3.11.1 PA System shall comply with the following power requirements:

- a) each PA System rack shall be equipped with two 20 A circuits terminated on L5-20R receptacles;
- b) each receptacle used by the PA system rack shall be placed on a different circuit and a second NAC must be connected to the second circuit in the rack, and between the two NAC's in that rack to provide A/B redundant power; and
- c) public address systems shall be connected to the emergency power and UPS.

7.3.11.2 PA system shall comply with the following network connectivity requirements:

- a) all NetSpire™ CONAC01/6020/USL NAC's shall be installed within a dedicated PA cabinet in the main Telecommunication Room at each GO Facility location;
- b) each NetSpire™ CONAC01/6020/USL NAC shall be provided with the IP connection for transfer of control and media content;
- c) each NetSpire™ CONAC01/6020/USL NAC shall be connected to the Metrolinx network switches with proper network configuration; and
- d) each NetSpire™ CONAC01/6020/USL NAC shall be connected to the separate network outlet.

7.3.11.3 PA system shall comply with the following network time requirements:

- a) the PA system shall support the automatic adjustment of clock changes related to daylight savings time; and
- b) the PA system shall support syncing to an NNTP server for updates to the internal clock.

7.3.11.4 PA system shall comply with the following ambient noise requirements:

- a) NetSpire™ AUMIC03 ANS microphones connected to the NetSpire™ CONAC01/6020/USL shall be installed in an optimum location for background noise level monitoring.

7.3.11.5 PA system shall comply with the following PA system rack requirements:

- a) Dedicated PA communication rack shall be installed within Metrolinx main Telecommunication Room to host NetSpire™ CONAC01/6020/USL NAC's and other devices as part of PA system deployment package.

7.3.12 Network connectivity

- 7.3.12.1 Each NetSpire™ CONAC01/6020/USL NAC shall be provided with the IP connection for transfer of control and media content.
- 7.3.12.2 Each NetSpire™ CONAC01/6020/USL NAC shall be connected to Metrolinx network switches with proper network configuration.
- 7.3.12.3 Each NetSpire™ CONAC01/6020/USL NAC shall be connected to the separate network outlet.
- 7.3.12.4 The PA system shall support the automatic adjustment of clock changes related to daylight savings time.
- 7.3.12.5 The PA system shall support syncing to an Nntp server for updates to the internal clock.

7.3.13 Ambient level sensing microphones

- 7.3.13.1 NetSpire™ AUMIC03 ANS microphones shall be connected to the NetSpire™ CONAC01/6020/USL and installed in an optimum location as determined by the Acoustics Study to monitor background noise levels.

7.4 Digital Signage

7.4.1 General

- 7.4.1.1 A Digital Signage system shall be provided to communicate trip information, notifications, infotainment and advertising to Metrolinx bus and rail customers.
- 7.4.1.2 The outdoor Digital Signage system shall incorporate LCD monitors with either 46-47 " or 55 " screens.
- 7.4.1.3 The indoor Digital Signage system shall incorporate LCD monitors with the 49 " screens.
- 7.4.1.4 The indoor and outdoor Digital Signage systems shall incorporate LCD monitor makes/models, aligning with the current Metrolinx I&IT list of qualified monitors.
- 7.4.1.5 Each Digital Signage system shall incorporate a software media player facilitating information display on the monitors. The player make shall align with the current Metrolinx I&IT list of qualified digital media players (referred to asDMP hereafter in this document). If DMP doesn't have HDMI output, an adapter to convert the output to HDMI will be needed.
- 7.4.1.6 All DS components in the Telecommunications Room and the NEMA enclosures shall be mounted on DIN rails.

7.4.2 Access Control

- 7.4.2.1 The access to the rear of the LCD monitors used in the Digital Signage systems shall be restricted (tamper resistant) and not accessible to the public.
- 7.4.2.2 The overhead LCD monitors shall be mounted at the height of minimum 2.4 m from the facility floor to the bottom of the monitor.
- 7.4.2.3 NEMA Enclosures shall be provisioned with the lock and a key, to prevent unauthorized access.
- 7.4.3 Connectivity
 - 7.4.3.1 The LCD monitors in the Digital Signage system shall be provisioned with the minimum of one outdoor rated Category 6E network outlet, connected to the nearest Telecommunications Room network rack, switched equipped NEMA box, or platform mini hub room, and terminated in accordance with the copper horizontal cabling requirements in Section 6.3.2.
 - 7.4.3.2 All cabling between the LCD monitors and the Telecommunications Rooms shall be enclosed in an appropriately sized conduit as prescribed in the Standard Specifications. All cables used in conduits shall be outdoor rated and any cables installed in underground conduits or duct banks shall be of burial rated cable grade.
 - 7.4.3.3 Outdoor copper cabling used shall be Category 6 outdoor rated when installed in conduit, and any cables installed in underground conduits or duct banks shall be of burial rated cable grade.
 - 7.4.3.4 Minimum Category 6a or better shielded cable shall be used to connect the LCD monitors placed within 90 m from the Telecommunications Room.
 - 7.4.3.5 Single mode 6 strand fibre optic cable shall be used to connect the LCD monitors placed further than 90 m from the Telecommunications Room, and shall be terminated as specified in Section 6.
 - 7.4.3.6 A media converter shall be located near the endpoint device location in order to convert fibre to copper (PoE). If the media converter is located in the unconditioned space or outdoors, it shall be enclosed in a NEMA 4X box. The Media Converter shall be powered on the display's end.
 - 7.4.3.7 HDBaseT sender with PoE ability shall be used to extend the HDMI signal from the Digital Media player over Category 6a shield cable to HDBaseT receiver, enclosed in NEMA 4X box on the display's end.
 - 7.4.3.8 HDBaseT sender shall be located in the Telecommunications Room and shall be powered with power adapter and plug connected to power outlet.
 - 7.4.3.9 HDBaseT receiver with PoE ability shall be used and powered by PoE remotely.
- 7.4.4 Power
 - 7.4.4.1 The LCD monitors in the Digital Signage system shall be connected to the dedicated 20A duplex outdoor-rated GFI and surge protector.

- 7.4.4.2 A/B type redundancy shall be provided to mitigate total blackout if one circuit is compromised.
- 7.4.4.3 Drip loops shall be used in wiring feeding into the environmentally controlled enclosure.
- 7.4.4.4 The power outlet shall support up to 800 W power consumption for the outdoor monitor and up to 250W power consumption for the indoor monitor.
- 7.4.5 **Availability**
 - 7.4.5.1 The Digital Signal System shall be backed-up by the UPS/generator system in times of power outages.
- 7.4.6 **Other requirements**
 - 7.4.6.1 Headend media converters in the Telecommunications Room(s) shall be rack mounted.
 - 7.4.6.2 The enclosure size selection shall be based on the electrical and electronic equipment to be housed inside the box. A single NEMA 4X box can be utilized to support the installation of two LCD monitors installed back-to-back.
 - 7.4.6.3 All NEMA enclosures shall be concealed within poles or finishes adjacent to screens, not visible from outside.
 - 7.4.6.4 NEMA enclosure placement shall be designed to allow access by the authorized users.
- 7.4.7 **Installation diagram**
 - 7.4.7.1 When mini hub rooms are not present, the installation shall be performed as in Figure 9.
 - 7.4.7.2 When mini hub rooms are present, the installation shall be performed as in Figure 10.

Figure 9: Installation diagram when hub rooms are not present

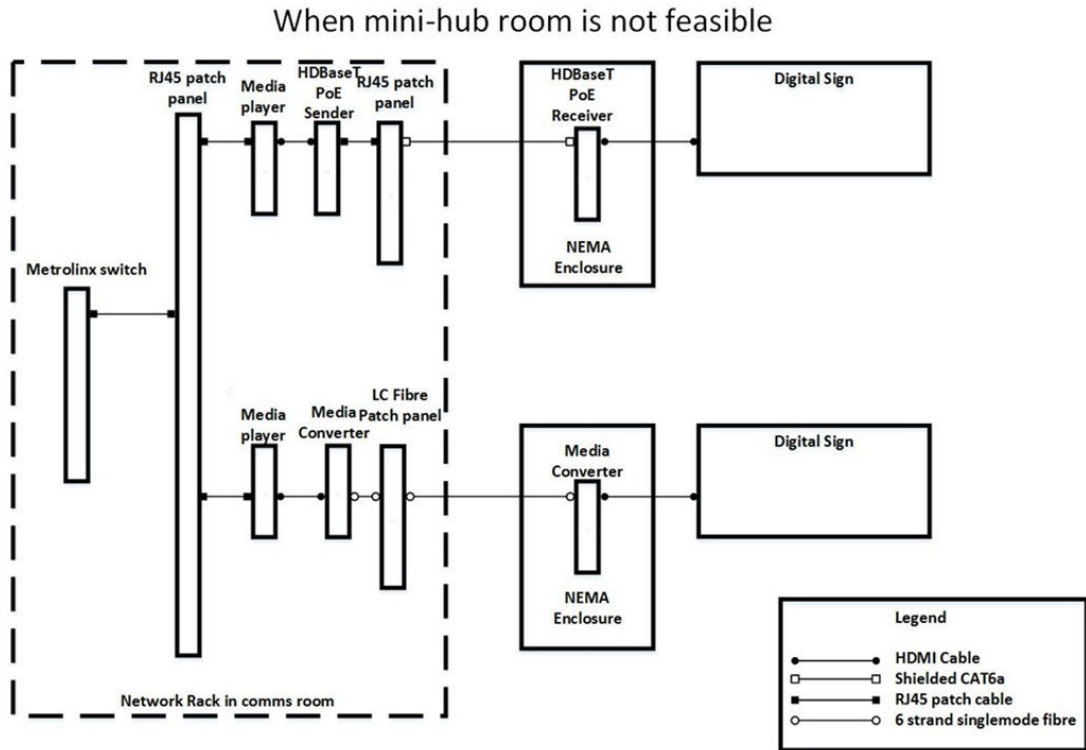
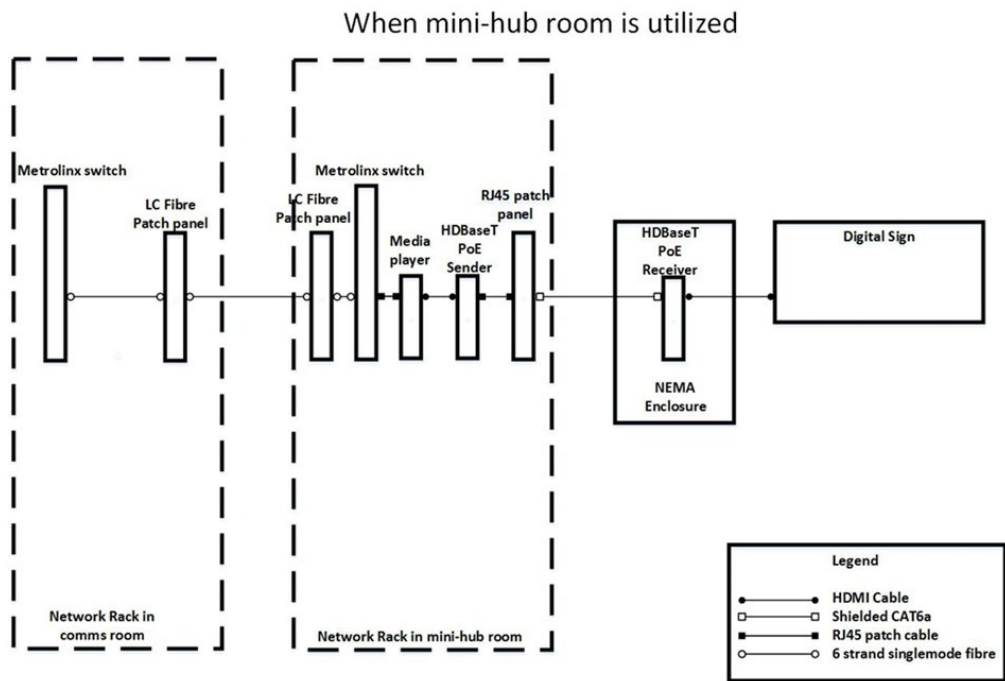

Figure 10: Installation diagram when hub rooms are built



7.5 Two-Way communication system

7.5.1 General

7.5.1.1 Installation of intercoms shall comply with reach and space ranges under the Metrolinx Universal Design Standard DS-02

7.5.1.2 Enhanced two-way intercom shall be provided at the DWA and shall be equipped with a localized AFILS and visual display and input device (keyboard) to support text communication (text input and output).

7.5.1.3 Intercom devices and system shall be provided to allow fast and direct communication for callers to speak to groups within Metrolinx to seek any assistance for both emergency and information calls. Calls originated from emergency intercom button and informational intercom button shall be routed and handled differently based on the requirements and programming.

7.5.1.4 Intercom devices (inside elevator intercom excluded) shall be IP based and shall support the RFC3261 SIP .

7.5.1.5 Analog elevator cab intercoms shall be provided with analog connectivity (Category 3) for remote monitoring.

7.5.1.6 IP based Intercom devices shall be able to integrate with Metrolinx Enterprise PBX (Cisco Unified communication system).

7.5.1.7 IP based Intercom devices shall provide a web based tool for Metrolinx to manage the configuration and intercom call routing.

7.5.1.8 Intercom devices shall be equipped with localized AFILS.

7.5.2 Intercom system infrastructure

7.5.2.1 Intercom systems connected with copper infrastructure shall be located within 90 m of a hub room.

7.5.2.2 Intercom systems connected with fibre infrastructure shall comply with the following:

- a) use single-mode fibre in accordance with the requirements of Section 6;
- b) used only when there are no hub rooms within 90 m of the device;
- c) fibre transceivers must be located in the nearest hub room to the device;
- d) the transceiver at the device end shall be located in a NEMA 4X rated enclosure;
- e) the NEMA enclosure must have separate zones for power and data;
- f) all internal components shall be mounted on DIN rails;
- g) the enclosure shall be lockable; and
- h) power and data components shall be installed in accordance with ESA.

- 7.5.2.3 Device conduits shall be in accordance with the requirements of Metrolinx Standards.
- 7.5.2.4 Intercom shall comply with the following power requirements:
- a) IP based devices shall be powered via PoE where applicable; and
 - b) inside Elevator Analog intercom shall be powered via analog telecom provider line.
- 7.5.2.5 Intercom shall comply with the following network requirements:
- a) IP connectivity to the Metrolinx network shall be via a Metrolinx switch located in the nearest hub room;
 - b) analog connectivity to the telecom provider Demarc point is via Category 3 twisted pair cables;
 - c) the Network Infrastructure shall be monitored on both ends to ensure device communications are available, using Cisco Prime, HP OpsBridge and Microsoft SCOM systems;
 - d) inside elevator cab analog intercom shall be monitored by Chubb;
 - e) IP address assignment and management shall follow Metrolinx Standards; and
 - f) Intercom devices shall support Network QoS aligning with the Metrolinx I&IT VoIP QoS standard.
- 7.5.3 Intercom integration
- 7.5.3.1 Intercom device shall work in conjunction with access control systems, based on requirements for specific locations.
- 7.5.4 Elevator
- 7.5.4.1 The elevator Intercom shall comply with the following:
- a) manufacturer standard analog intercom shall be installed inside each elevator car.
 - b) inside elevator two way communication solution shall include a means to monitor and verify the operability of communication lines.
 - c) inside elevator Intercom device shall be equipment with an AFILS.
 - d) required cables shall be provided to connect inside elevator intercom to dedicated Metrolinx Telecommunications Room.
 - e) all intercoms at all required locations shall be compliant to AODA. In addition, Intercom in elevator shall conform to Technical Standards and Safety Authority (TSSA) and shall be compliant with Appendix E of ASME A17.1/CSA B44.

- f) cables for connecting inside elevator intercom shall be in accordance with the requirements of Section 6.

7.5.5 Universal washroom

7.5.5.1 The Universal washroom intercom shall comply with the following:

- a) an SIP based IP intercom shall be installed inside universal washroom;
- b) an audible and visual signal device shall be installed outside universal washroom;
- c) the inside universal washroom intercom shall be equipped with an AFILS; and
- d) required cables shall be provided to connect inside washroom intercom to Metrolinx Telecommunication Room in accordance with Section 6.

7.5.6 Technical specifications

7.5.6.1 All intercoms shall have the ability to be programmed to accept any standard DTMF codes and to route the calls based on business requirements.

7.5.6.2 The Intercom devices shall be configured with the three call flows, based on installation locations, including elevator, emergency, and informational calls.

7.5.6.3 The source device shall be configured with a call list to initiate a call flow. In the scenario when a button is pressed in an elevator, the device shall be configured to contact the appropriate extension or the outside party. Should the first number be unreachable, the device will continue dialing a call list of a maximum of six numbers, until the call is answered.

7.5.6.4 The Intercom device shall support call priority for the cases when an emergency button is depressed on the device during the 'information call' being underway, or not being answered. In this scenario, the 'emergency' call flow shall be initiated, terminating any current calls in progress.

7.5.6.5 The device shall be responsible for handling the call tree on its own; however, there might be a need to utilize the Cisco CUCM PBX platform in order to route calls based on schedule, availability and priority of the call.

7.5.6.6 The users receiving the calls shall have the ability and training required to conference, or to initiate the separate calls to 911 services, outside translation services and internal extensions.

7.5.6.7 The end of line devices or the intercoms shall be subject to installation location. The locations and type of intercoms described in Table 8 shall be used as reference only; the final type of intercoms installed for each location shall be dictated by the building drawings.

Table 8: Intercom model types

Location	Preferred device type	Model
Passenger assistance Intercoms (elevator landings, accessibility ramps, tunnels, parking lots, walkways, waiting areas)	Intercom with localized induction loop	Commend USA SIP-WS 210V DA
Gate /door access intercom, exterior building	1 – button information device with built in camera	Commend USA WS311V CM
Intercom inside building	1 – button information device	Commend USA SIP-WS 200V
DWA adjacent to Mini-platform	Intercom with induction loop and visual display and input device	To be provided by Elevator manufacturer

- 7.5.6.8 Two way (full duplex, simultaneous two ways) communication to or from the Intercom device shall be provided to ensure proper audibility with the end user. This shall be provided by utilizing Metrolinx enterprise PBX Unified Communications solution.
- 7.5.6.9 Intercom infrastructure shall provide ability to manage the call routing and scheduling functionality required to achieve the call flows described above. This also ensures that the call recipient (including 911 PSAP personnel) is informed of the Intercom’s location for every call.
- 7.5.6.10 Intercom shall allow two way calls to the end device as an extension of the Metrolinx PBX CUCM infrastructure in the case of a disconnected call situation, or for other purposes. Intercom devices shall be configured to not allow inbound calls.
- 7.5.6.11 The Intercom devices shall also have the ability to register with both data center facility Enterprise PBX CUCM systems to ensure that calls will be routed to destination through Enterprise failover mechanism in case of the VoIP failover event.
- 7.5.6.12 The Intercom devices shall have the ability to accept inbound DTMF codes to actuate local gates, and other local relay interfaces.
- 7.5.7 Central device monitoring and alerting
 - 7.5.7.1 A device monitoring and management solution shall be provided to ensure device availability and usability.
 - 7.5.7.2 The device monitoring system shall integrate with the Metrolinx I&IT central monitoring infrastructure. This monitoring shall be done usingSNMP v2 higher protocols on the IP Network. Both regular polling for device availability and system error events shall be sent directly to the central monitoring

- system which will subsequently notify Metrolinx I&IT personnel of device failures. Internal procedures shall be developed to ensure the appropriate response is given to these devices.
- 7.5.7.3 The device management system shall provide the ability to manage and configure end devices in batches, or individually. It shall also have the ability to deliver firmware, and other updates to the end devices in a batch method to ensure devices are kept current.
- 7.5.7.4 The device monitoring solution shall also record all activities of the device. This includes the events related to button activations, configuration activities, report all failures and device availability statistics. All of these activities shall be stored centrally in an auditable database to ensure compliance with regulations and to provide auditability.
- 7.5.8 Installation
- 7.5.8.1 The Contracted Party shall provide all components indicated on the contract drawings such as supports, bollards, conduits, raceways, device boxes, enclosures, cable, wires, connectors, equipment, controls, devices, controllers, intercom stations, relays, interfaces, programming and any other components, to ensure the intercom system is completely installed and satisfactorily operating, as indicated in the contract drawings.
- 7.5.8.2 The Contracted Party shall provide any other equipment, labor or material necessary to fulfill the functional and performance criteria of the system whether shown in the specification or contract drawings or not.
- 7.5.8.3 The Contracted Party shall work with Metrolinx I&IT for network connection and configuration.
- 7.5.8.4 The Contracted Party shall work with Metrolinx I&IT to integrate intercom with Metrolinx existing systems.
- 7.5.8.5 The Contracted Party shall work with Metrolinx I&IT to program the intercom based on Metrolinx business requirements.
- 7.5.8.6 The Contracted Party shall ensure the installation and systems integration work is performed by persons who are factory authorized and trained on the specified products.
- 7.5.8.7 On request by Metrolinx, the Contracted Party shall provide, within five Business Days of the request, a copy of training certificates issued by the manufacturer related to the products being installed.

7.6 Fare Systems (Devices)

- 7.6.1 General
- 7.6.1.1 Fare Systems shall be provided to support the fare payments and tickets processing at GO Facilities. The Fare Systems comprise of the following devices:
- a) SPOS;

- b) SFTP;
- c) handheld card reader and the hand card reader cradles;
- d) concentrator complex;
- e) add value machine;
- f) ticket vending machine; and
- g) fare vending machine.

7.6.2 Fare Devices

7.6.2.1 Remote locations shall be provided with two Fare Systems devices on different circuits, to provide redundancy in case of power failure.

7.6.2.2 Fare Devices shall conform to the following electrical connectivity and wiring requirements:

- a) wiring and circuit protection of the Fare Systems devices shall be sized to suit the total wattage on circuit, to address potential voltage drops, and de-rating requirements for multiple circuits run in the same conduit;
- b) the power requirements for each device shall be as described in Table 9.

Table 9: Fare Device power ratings

Device	Watts
SPOS	200
SFTP	35
Handheld card reader cradles	120

- c) cables from the Fare Systems devices shall run to the Metrolinx communication racks. Refer to this document, Specification Standard for Telecommunications Room(s), for more details;
- d) Metrolinx patch panels shall be used to terminate the cabling from the Fare Systems devices in accordance with the requirements of Section 5 and Metrolinx Standards;
- e) type of cabling (Copper vs. Fibre) connecting Fare Systems devices to Metrolinx network shall depend on the distance from the Telecommunications Room in accordance with Section 6 and Metrolinx Standards;
- f) the power for the fibre shall be run from the fibre NEMA enclosure to the Telecommunications Room rack;
- g) Fare Devices shall be run back to properly marked breakers at the emergency panel, except for stations that don't have the centralized UPS and generator;

- h) station UPS shall be used to provide back-up power to the Fare Devices as applicable; and
 - i) Fare Device access control requirements shall conform to the following:
Only authorized users shall have the access to the Fare Devices.
- 7.6.2.3 Fare Devices infrastructure and network security requirements shall conform to the following:
- a) the Contracted Party shall work with Metrolinx I&IT to complete the installation and connectivity of any Fare Systems;
 - b) conduits for power and telecommunications shall be included in the design and construction. Installation of the cabling is to be done prior to the arrival of the Fare Device, and shall be coordinated with the Fare Device installer; and
 - c) connectivity of the Fare Devices device shall be performed by Metrolinx I&IT.

7.7 Station Attendant's System

7.7.1 General

- 7.7.1.1 The system used in the station attendant's execution of their daily activities in assisting customers shall comprise of the following components, (the "Station Attendant's System"):
- a) sales wicket AIO computer: computer device primarily used by SAs to check their emails, RAMS ESR applications, print documents, use trip manager to assist customers in planning their trips, check schedule and do any other computer related daily tasks. HP EliteOne 800 G5 AIO (Part Number: 8GB38UP#ABA) shall be used as a reference AIO;
 - b) each station attendant workstation shall be equipped with a common phone line that is used by all the station attendants. There is usually only one phone per station, however, the larger stations are provisioned with two phones connected to the same phone number line (hunt group) that can be answered at the same time.
 - c) desk phone: desk phones shall also be connected to the PA systems and used for making PA announcements at the stations. Cisco IP Phone 8851 VoIP phone (Part Number: CP-8851-K9)) shall be used as the reference desk phone;
 - d) CCTV computers (HP EliteDesk 800 G5 Desktop mini (Part Number: 7LJ66UT#ABA)): computer devices used to monitor all the live CCTV cameras at the station using Indigo Vision application. These computers are configured to disable the inactivity lockout. HP EliteDesk 800 G5 Desktop mini (Part Number: 7LJ66UT#ABA) shall be used as a reference CCTV computer;

- e) network printers: printers used to print electronic sales reports at the end of the day and general printing HP PageWide Enterprise Color MFP 586dn (Part Number: G1W39A#BGJ) shall be used as the reference network printer;
- f) back office computer: computer device primarily used by station attendants to create balance sheets at the end of their shift; HP EliteOne 800 G5 AIO (Part Number: 8GB38UP#ABA) or HP EliteDesk 800 G5 Desktop mini (Part Number: 7LJ66UT#ABA) and HP EliteDisplay E233 (Part Number: 1FH46A8#ABA) shall be used as the reference back office computer;
- g) drivers room computer: computer device primarily used by bus drivers and bus operations supervisors; HP EliteDesk 800 G5 Desktop mini (Part Number: 7LJ66UT#ABA) and HP EliteDisplay E233 (Part Number: 1FH46A8#ABA) shall be used as the reference drivers room computer (depending on location);
- h) transit safety office room computer: Primarily used by transit safety officers based from that office to do their daily tasks, HP EliteDesk 800 G5 Desktop mini (Part Number: 7LJ66UT#ABA) and HP EliteDisplay E233 (Part number: 1FH46A8#ABA) shall be used as the reference transit safety office room computer (depending on location); and
- i) peripherals: station PC requires a keyboard and mouse as well as a monitor on-top of the station attendant's desk. The purchase and installation of this PC is the responsibility of Metrolinx I&IT (keyboard and mouse are included on the new computers (AIO and Desktop MINI)).

7.7.1.2 Station attendant's PC power requirements shall comply with the following:

- a) including Monitor, PC, KVM, and other devices, a minimum of two 20 A Duplex Receptacles on UPS Power are required;
- b) the receptacles shall not be ganged (bolted) into a single box and must allow for a minimum of 100 mm between outlets; and
- c) the outlets shall be located within close proximity to the PC location within the desk. Refer to standard GO Transit Service Counter Drawings for further details.

7.7.2 Service counter point to point two way talk system requirements

7.7.2.1 Service counter point to point two way talk system shall be a standalone system, providing the staff /customer voice communication over the glass wall counter. This system does not require integration with the Enterprise PBX system ticket booth. The point to point two way talk system shall comply with the following requirements:

- a) ticket booth point to point two way talk system device shall provide two-way communication between staff and customer over the counter which normally separated by glass;

- b) the over the counter point to point Intercom device shall be equipped with an built-in AFILS;
- c) the over the counter point to point intercom device shall be equipped with both staff side and customer side amplified speakers and microphones to ensure the clarity of the voice communication;
- d) required cables shall be provided to connect all components in accordance with Section 6;
- e) other than speakers and microphones, the rest of the system components shall be installed under the counter table; and
- f) service counter point to point two way talk system shall use Amptronic TalkPerfect DX Speech enhance system

7.7.3 Service counter fax / printer devices

7.7.3.1 Each service counter shall have a network printer, fax and copier device. This device shall be located on the electrical drawings along with the location of the below network and power outlets.

7.7.3.2 Service counter fax / printer devices shall comply with the following millwork requirements:

- a) a location for the service counter fax / printer devices device shall be identified within the ticket sales area. This location is to be determined by Metrolinx Station Operations;
- b) the physical dimensions of the Service Counter Fax / Printer unit clearance shall be (W x D x H): 22 x 762 x 26 in. (558 x 665 x 660mm) and shall be accommodated within the millwork space;
- c) the dimensions are subject to change and Metrolinx I&IT shall be contacted for latest specifications; and
- d) additional clearance above the service counter fax / printer unit shall be provided for operation of the top tray of the MFP. There shall be no obstructions within 24" or 610 mm above the unit.

7.7.3.3 Service counter fax / printer devices network connectivity shall comply with the following:

- a) each of service counter fax / printer devices requires a minimum of two network outlets;
- b) the network outlets shall be cabled back to the nearest Telecommunications Room network rack and terminated in accordance with the copper horizontal cabling requirements in Section 6.3.2; and
- c) the network outlets shall be used for both fax and data lines from the Telecommunications Room.

- 7.7.3.4 Service counter fax / printer devices shall comply with the following power requirements:
 - a) each service counter fax / printer device locations requires a single 20 A duplex receptacle; and
 - b) emergency / backup power shall be provided but does not need to be a dedicated circuit.
- 7.7.3.5 Service counter shall be configured in accordance with Figure 11.

Figure 11: Typical service counter example

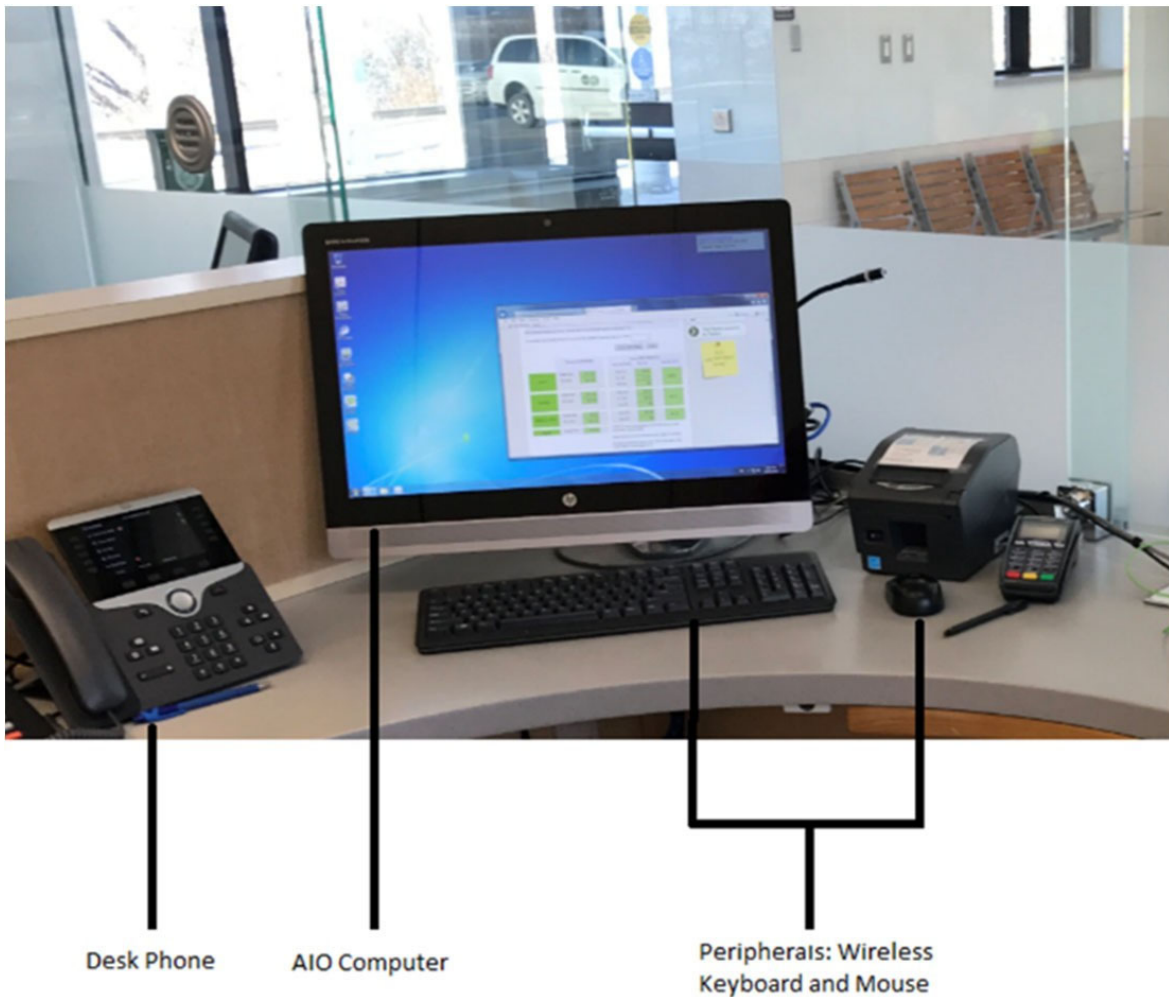

7.8 Cellular distributed Antennae system

- 7.8.1 General
 - 7.8.1.1 The DAS systems shall provide and enhance the cellular coverage at GO Facilities and Office Buildings, including voice and data, for Metrolinx staff and the visitors attending these facilities, as well as to the emergency services (fire/ambulance/police) operating in the proximity of these facilities. Metrolinx also

- uses DAS systems for UHF/VHF Radio Communications to facilitate Train Operations, Security and Life Safety.
- 7.8.1.2 Cellular phone services are controlled by third party providers that require the use of licensed radio frequencies. Different service providers use various technologies when sending and receiving cellular signals. The Contracted Party shall coordinate with these third party providers to extend cellular signals onto GO Facilities and into Office Buildings.
- 7.8.1.3 The DAS systems shall be designed to be carrier neutral and to operate simultaneously by any authorized cellular telecommunication carrier such as Bell/TELUS, Rogers, Shaw (Freedom), Videotron, or any carrier with a valid and current federal license to cellular spectrum in Canada.
- 7.8.1.4 The DAS systems shall contain all components required for operation, including cables, antennae, and the carrier radio equipment, while utilizing dedicated carrier conduits, cable pathways, radio and telecom spaces (main and remote radio rooms) in accordance with cellular telecommunication carrier requirements. There may be several DAS systems in place at a single facility, including the support for Emergency Services providers.
- 7.8.1.5 The DAS systems shall be deployed allowing for maximized cellular coverage available at Metrolinx facilities.
- 7.8.1.6 The DAS system shall use single mode fibre communications and the power support provided by Metrolinx, in accordance with agreement between the DAS system vendor and the Metrolinx.
- 7.8.1.7 The DAS system deployment shall provision for the emergency DAS system to be installed in conjunction with the primary DAS. Provide a high level of radio connectivity for emergency responders to ensuring public safety.
- 7.8.1.8 Coverage on platforms and other outdoor areas shall be designed by carriers so as to coexist with nearby cellular towers that exist in the nearby locations.
- 7.8.1.9 When designing the DAS system, the following shall be considered:
- a) specification for the number and type of Antenna's;
 - b) placement of cabling, and signal distribution equipment in buildings;
 - c) availability of suitable space in existing and historical buildings; and
 - d) placement of carriers' equipment for connections to the DAS or the "head end":
 - 1) capacity of the facility's fibre network to connect Head End and distribution equipment across site; and
 - 2) back-up power requirements including UPS and generators.
- 7.8.2 Information protection

- 7.8.2.1 The DAS system providers shall be responsible for protection of the cellular data received / transmitted by DAS.
- 7.8.2.2 The DAS system providers shall comply with rules, regulations and frequencies specified by the CRTC in Canada and all other regulations that apply.
- 7.8.3 Access control
 - 7.8.3.1 The DAS system shall be carrier-neutral, accessible by all licensed telecommunications carriers, and shall support all licensed spectrums.
 - 7.8.3.2 The DAS system shall allow for simultaneous access by all supported telecommunication carriers.
- 7.8.4 Security
 - 7.8.4.1 The DAS systems shall be secured in accordance with Good Industry Practice.
- 7.8.5 Capability and scalability
 - 7.8.5.1 The DAS systems deployment shall be designed to accommodate the 50% future growth, including all dedicated carrier conduits, cable pathways, radio and telecom spaces.

7.9 Enterprise Wi-Fi

- 7.9.1 General
 - 7.9.1.1 Enterprise wi-fi shall be provided as an internal service available to Metrolinx employees using authorized devices and registered guests (internet only) at GO Facilities and Office Buildings locations as directed by Metrolinx.
 - 7.9.1.2 Third-party procurement of any wireless related equipment such as wireless APs or wireless controllers shall be registered to Metrolinx I&IT prior to handover of the project.
 - 7.9.1.3 All Metrolinx sites shall have a radio frequency study to characterize licensed and unlicensed radio spectrum per location prior to the per building/floor/area wi-fi design work, (the "RF Study"). The RF Study shall be submitted to Metrolinx for review.
 - 7.9.1.4 All GO Facilities and Office Buildings shall have a predictive wi-fi site survey, (the "Wi-Fi Site Survey") completed prior to the sign off of construction drawings. The Wi-Fi Site Survey shall include:
 - a) the current recommended Metrolinx AP defined; and
 - b) support for VoIP devices.
 - 7.9.1.5 All GO Facilities and Office Buildings shall have a pre-deployment wi-fi site survey completed, (the "Pre-Deployment Wi-Fi Site Survey"). The Pre-Deployment Wi-Fi Site Survey shall include:
 - a) the current recommended Metrolinx AP defined; and

- b) support for VoIP devices.
- 7.9.1.6 All GO Facilities and Office Buildings shall have a post installation wi-fi site survey completed after the installation of the wi-fi Aps, (the "Post Installation Wi-Fi Site Survey"). The Post Installation Wi-Fi Site Survey shall include:
 - a) the current recommended Metrolinx AP defined; and
 - b) support for VoIP devices.
- 7.9.1.7 All wi-fi surveys identified in Sections 7.9.1.4, Section 7.9.1.5, and Section 7.9.1.6 require Metrolinx acceptance to validate coverage and capacity requirements.
- 7.9.1.8 There shall be wi-fi coverage providing connectivity for full coverage of the entire office floor areas, including indoor bus and rail offices. Metrolinx will identify areas of exclusion on the floor plans provided.
- 7.9.1.9 The wi-fi coverage and capacity requirements shall be determined by Metrolinx.
- 7.9.1.10 There shall be wi-fi coverage providing connectivity for predetermined outdoor areas in the indoor and outdoor rail maintenance and layover storage facilities. Site plans shall be submitted to Metrolinx for review and these areas shall be identified by the Metrolinx, I&IT Solution Manager.
- 7.9.2 Indoor office Access Points
 - 7.9.2.1 Indoor AP specifications: Refer to Table A-4 in Appendix A.3 for AP model information.
 - 7.9.2.2 The APs shall be connected to an 802.3at PoE+ (31 W), 1000/2500/5000 Multi-gigabit (RJ-45) Ethernet switch port supporting IEEE 802.3bz.
 - 7.9.2.3 In the locations where 802.3bt Type 3 "4PPoE" (60 W) or 802.3bt Type 4 (100 W) switches are required for external cameras with heated enclosures, or for the outdoor WAPs, the proper power injector shall be provided along with documentation on which devices are controlled by which injector (by labelling each injector). The vendor shall indicate location of power injector on "final as built" drawings for day two support.
 - 7.9.2.4 In office locations with open plenum ceiling tile environments, a single plenum Category 6a or higher (Pending Metrolinx acceptance) cable grade shall be used to connect the APs.
 - 7.9.2.5 The cabling to Access Points shall conform to all of the suspended ceiling cable termination requirements in Metrolinx Standards.
 - 7.9.2.6 The APs that are installed in ceilings with tiles shall be installed with the lowest visible impact to the office ceiling.
 - 7.9.2.7 Each AP shall be properly oriented and mounted with a proper Metrolinx approved method and the appropriate mounting bracket.
 - 7.9.2.8 The APs in areas which do not have a standard office ceiling tile environment, and feature an open web joist, flat drywall, concrete type ceiling or other similar

- implementation shall have conduit installed directly to a standard electrical box fitting the mounting bracket for the supplied Wireless AP. The bracket shall be mounted directly to the electrical / telecommunications junction box face.
- 7.9.2.9 All data cabling shall be run through this conduit.
 - 7.9.2.10 A minimum of 300 mm of slack cable shall be left within the junction box after termination to allow for easy replacement and re-termination, if necessary. All junction boxes shall be mounted in a secure fashion and shall support the full weight of the specified access point.
 - 7.9.3 Indoor bus and rail storage and maintenance facilities access point
 - 7.9.3.1 Wireless APs shall be installed in all bus garage and maintenance facilities allowing for the complete coverage of all areas of the facility.
 - 7.9.3.2 Metrolinx will identify areas of exclusion on provided floor plan. This excludes staff parking lots and staff parking garages unless specifically indicated.
 - 7.9.3.3 The AP shall not be installed in locations that are harsh in nature (e.g. close proximity to hazardous materials, or vehicle washing facilities). Refer to Table A-4 in Appendix A.3 for AP model information.
 - 7.9.3.4 The AP shall have an omnidirectional Antenna option: 4 external 2.4Ghz/5Ghz Dual Band Antenna per each AP installed. Refer to Table A-4 in Appendix A.3 for model information.
 - 7.9.3.5 For patch Antenna with 6 dbi Gain, the 2.4 Ghz/5 Ghz Dual-Band Polarization Diverse Antenna shall be provided per each AP installed. Refer to Table A-4 in Appendix A.3 for model information.
 - 7.9.3.6 For patch Antenna with 13 dbi Gain, 2.4 Ghz/5 Ghz Dual-Band Polarization Diverse Antenna shall be provided per each AP installed. Refer to Table A-4 in Appendix A.3 for model information.
 - 7.9.3.7 The APs shall be connected to the 802.3 at PoE+ (31 W), 1000/2500/5000 Multi-gigabit (RJ-45) ethernet switch port supporting IEEE 802.3bz.
 - 7.9.3.8 All AP shall utilize a single Category 6a or higher cable grade, subject to Metrolinx acceptance, for network connectivity.
 - 7.9.3.9 A minimum of 300 mm of slack cable shall be left within the junction box after termination to allow for easy replacement and re-termination, if necessary.
 - 7.9.3.10 The cabling to APs shall conform to all of the suspended ceiling cable termination requirements in Metrolinx Standards.
 - 7.9.3.11 All APs must have conduit installed directly to a standard electrical box fitting the mounting bracket for the supplied WAP, mounted directly to the electrical / telecommunications junction box face.
 - 7.9.3.12 All data cabling shall be run through this conduit.

- 7.9.3.13 All junction boxes shall be mounted in a secure fashion and shall support the full weight of the specified AP.
- 7.9.4 Outdoor rail maintenance (storage) and layover facilities Access Points
 - 7.9.4.1 WAPs shall be installed in all outdoor rail maintenance and layover facilities to provide coverage to the train consists. At minimal the coverage must include the coverage for locomotive, the 5A coach car (middle of the train consist) and the cab car (10-12th coach). Refer to Table A-4 in Appendix A.3 for AP model information.
 - 7.9.4.2 These APs shall be used in outdoor areas, or are in harsh indoor environments (e.g. close proximity to hazardous materials, or vehicle washing facilities). Refer to Table A-4 in Appendix A.3 for model information.
 - 7.9.4.3 For omnidirectional Antenna, the AP requires 4 external 2.4 Ghz/5 Ghz Dual Band Antenna per each AP installed. Refer to Table A-4 in Appendix A.3 for model information.
 - 7.9.4.4 For patch Antenna with 8 dbi Gain, the 2.4 Ghz/5 Ghz Dual-Band Antenna shall be provided per each AP installed. Refer to Table A-4 in Appendix A.3 for model information.
 - 7.9.4.5 For patch Antenna with 13 dbi Gain, 2.4 Ghz/5 Ghz Dual-Band Polarization Diverse Antenna shall be provided per each AP installed. Refer to Table A-4 in Appendix A.3 for model information
 - 7.9.4.6 To enable the GPS feature in the Cisco 1572EAC AP, an optional Cisco part number AIR-ANT-GPS-1 external antenna shall be provided. Refer to Table A-4 in Appendix A.3 for model information.
 - 7.9.4.7 The outdoor APs shall be pole, wall, or ceiling mounted and shall be installed in accordance with the manufacturer's instructions.
 - 7.9.4.8 The APs shall be fastened securely to prevent theft or damage to the equipment, with the appropriate hardware for the installation included.
 - 7.9.4.9 All final hardware and mounting methods are subject to Metrolinx inspection and acceptance.
 - 7.9.4.10 The outdoor AP shall be connected to 120 VAC power supply.
 - 7.9.4.11 Communications and power for all outdoor AP devices shall be enclosed within a NEMA 4X box.
 - 7.9.4.12 All internal components shall be DIN rail mounted.
 - 7.9.4.13 Power and communications shall be physically separated within the NEMA box, power shall be installed along the bottom-mounted DIN rail and communications along the top-mounted DIN rail The NEMA enclosures shall be appropriately sized house a duplex receptacle, fibre termination jacks, and fibre transceiver hardware, with the minimum dimensions of 300 mm x 300 mm x 150 mm.
 - 7.9.4.14 All cables shall be Category 6E Ethernet type. Where a device is further than 90 m from the applicable hub room, single-mode fibre shall be used.

- 7.9.4.15 The APs shall be connected to 1000BASE-T ethernet switch port (RJ-45) when the copper interface is used.
- 7.9.4.16 The APs shall be connected to a fibre ethernet switch port (LC) when the fibre interface is used.
- 7.9.4.17 Category 6A or higher (subject to Metrolinx acceptance) cable grade shall be used to connect the AP's in Outdoor Rail Maintenance and Layover Facilities using the copper cable connection.
- 7.9.4.18 All data cabling shall be run through the dedicated conduit.
- 7.9.4.19 Single-mode fibre cable shall be used to connect the AP's in outdoor rail maintenance and layover facilities where required by distance limitations.
- 7.9.4.20 Any cables installed in underground conduits or duct banks shall be of burial rated cable grade.
- 7.9.4.21 All junction boxes shall be mounted in a secure fashion and shall support the full weight of the specified AP, with a minimum of 300 mm of slack cable left within the junction box after termination to allow for easy replacement, and re-termination if necessary.

7.10 Network (digital) clocks

7.10.1 General

- 7.10.1.1 Network clock shall be placed within direct sightlines of the station attendant, either within the GO service area or in the adjacent waiting area.
- 7.10.1.2 Network clocks shall support the adjustment of time to and from daylight savings, when receiving the appropriate update from the NTP server.
- 7.10.1.3 Network clock locations shall be indicated in the electrical drawings and is to include location of the below network and power outlets for review by Metrolinx.

7.10.2 Network

- 7.10.2.1 Each of these network clock devices shall have a minimum of one network outlet. The network outlets shall be cabled back to the nearest Telecommunications Room network rack and terminated in accordance with the copper horizontal cabling requirements in Section 6.3.2.

7.10.3 Power

- 7.10.3.1 Network clocks connected as PoE shall be backed up by the generator and / or UPS powering the network switch.
- 7.10.3.2 Network clocks connected to power outlets shall be powered by the backup generator / UPS powering the facility where the clock is installed.
- 7.10.3.3 Network clocks device locations require a single 20 A duplex receptacle.

7.10.4 Other requirements

- 7.10.4.1 The digital content displayed by the network clock shall comply with AODA or other applicable legislation.
- 7.10.4.2 The network clock shall be visible from the seated position or as required by AODA or other applicable legislation.
- 7.10.4.3 Outdoor network clocks shall be installed within an enclosure where required, suited to environmental conditions.
- 7.10.4.4 Outdoor network clocks shall be rated for operation between -40 to +50 degrees Celsius.

7.11 Time keeping / punch clocks

7.11.1 General

- 7.11.1.1 The location of the time clocks shall be determined by Metrolinx.

7.11.2 Network connectivity

- 7.11.2.1 Each of time keeping / punch clock devices shall have a minimum of one network outlet. These network outlets shall be cabled back to the nearest Telecommunications Room network rack and terminated in accordance with the copper horizontal cabling requirements in Section 6.3.2.

7.11.3 Power

- 7.11.3.1 Each of time keeping / punch clock device locations shall have a single 20A duplex receptacle. These devices do not need to be connected to UPS / emergency power and do not require a dedicated outlet. Electrical outlets shall be in accordance with Metrolinx Standards.

7.12 Building automation systems

7.12.1 General

- 7.12.1.1 BAS shall be provided in accordance with Metrolinx Standards for the monitoring and control of mechanical systems, electrical systems and other building components installed at GO Facilities and Office Buildings.

- 7.12.1.2 The location of the BAS control panel and location of the network outlets shall be included on the construction electronic drawings. This also applies to snow melt and other HVAC control systems where network connectivity is required.

7.12.2 Network connectivity

- 7.12.2.1 Monitoring and control relays and sensors shall be designed, installed, and deployed in accordance with Metrolinx Standards.
- 7.12.2.2 The Contracted Party shall be responsible for installation and connectivity of all the BAS in accordance with the requirements of Section 6 of this document, including compliance with the physical and logical isolation from the Metrolinx I&IT private network, so that no Metrolinx I&IT endpoint

- device (e.g., computers, laptops, servers, and any other computing device) can be reached to and/or from the monitoring and control relays and sensors via TCP/IP channels. This includes any intermediate connectivity devices such as hubs, switches, routers, firewalls, terminal units, and other associated devices.
- 7.12.2.3 BAS shall use IP addresses provided by Metrolinx I&IT.
 - 7.12.2.4 BAS system (i.e., compute, storage, network, and cabling components) installation shall be in accordance with Section 6 of this document and in accordance with Metrolinx Standards.
 - 7.12.2.5 Craftsmanship and quality of installation shall be reviewed and accepted by Metrolinx prior to and post installation.
 - 7.12.2.6 If integration with Metrolinx systems is required, this integration shall be in accordance with Section 6 of this document and Metrolinx Standards. The integration design shall be submitted for Metrolinx review and the installation, enhancements/upgrades, and replacement shall be subject to Metrolinx inspection and acceptance.

7.13 Building UPS telecommunications

- 7.13.1 General
 - 7.13.1.1 All Metrolinx UPS systems shall be connected to the Metrolinx network infrastructure for future monitoring.
- 7.13.2 Network connectivity
 - 7.13.2.1 Each building UPS telecommunication device shall have a minimum of two network outlets.
 - 7.13.2.2 The network outlets shall be cabled back to the nearest Telecommunications Room network rack and terminated in accordance with the copper horizontal cabling requirements in Section 6.3.2.

7.14 Fuel management systems

- 7.14.1 Rack installation
 - 7.14.1.1 Fuelling systems shall have an isolated facility room for their control and management systems. These rooms shall be isolated into a third party hub room independent from the Telecommunications Room and electrical room(s).
 - 7.14.1.2 Fuel management system shall be installed on the dedicated floor standing rack, with a minimum of 1.0 m clearance on three sides if it is placed alone in the dedicated room.
 - 7.14.1.3 The dedicated rack shall be a floor standing rack with a minimum of 1.0 m clearance on three sides. One side may be placed against the wall.

- 7.14.1.4 If installation is performed in the shared Telecommunication Room, the rack make, and model shall match the make and model as the other racks in the room and Metrolinx racks shall be ganged (bolted) together.
- 7.14.1.5 Standalone rack requirements shall be in accordance with Section 5.9.
- 7.14.1.6 Each rack location shall be provided with two 20A NEMA L5-20R outlets on the emergency UPS panel from the Telecommunications Room, placed on separate breakers. These outlets shall conform to Metrolinx Standards.
- 7.14.2 Network
 - 7.14.2.1 Fuel management system shall be connected with two Category 6 network cables, installed in the 2 x 53mm (minimum) conduits, in locations where the fuel management system rack is installed within 90 m of the Telecommunications Room. Conduit shall be provided in accordance with Metrolinx Standards.
 - 7.14.2.2 Fuel management system shall be connected with 12 strand single-mode fibre cable, terminated within the fuel management system rack using LC type terminations, in locations where the fuel management system rack is installed further then 90 m from the Telecommunications Room.
 - 7.14.2.3 A minimum of 2 x 53 mm conduits shall be provided from the fuel management system rack to the nearest Telecommunications Room for telecommunications and integration into the GO Transit network infrastructure. Conduit shall be provided in accordance with Metrolinx Standards.
 - 7.14.2.4 A minimum of 1 x 27 mm conduit shall be provided from this rack to the location of the fuel management system network switch for network data cables. This shall be coordinated with the fuel management system integrators. Conduit shall be provided in accordance with Metrolinx Standards.
 - 7.14.2.5 Fuel management system shall include provisions for the network switch to be installed into the fuel management system rack and integrated with the existing Metrolinx network infrastructure at the site. The fuel management system shall be connected to the switch with the network data cables installed in the 1 x 27 mm (minimum) conduits.
 - 7.14.2.6 The network switch installed for the fuel management system shall only be used for connection with Metrolinx network and shall only provide connectivity between fuel management server and the Metrolinx network. Conduit shall be provided in accordance with Metrolinx Standards.
 - 7.14.2.7 Fuel management system devices shall be installed on the dedicated, non-Metrolinx network. Switches provided by the fuel management system vendor shall never be used to support any non-fuel systems devices, such as Metrolinx CCTV, wi-fi or security systems.
 - 7.14.2.8 Fuel management system located greater than 90 m from the nearest hub room shall be connected back to the main fuel management systems rack on the separate fibre strands. Interconnection, management and maintenance of fuel

systems network devices including media converters, switches, routers, firewalls are the responsibility of the fuel systems supplier.

- 7.14.2.9 There shall be a single Metrolinx network server installed at each fuel management system location, to facilitate local data collection and authorization of the fuel delivery.
- 7.14.2.10 The network server applications shall be installed by the application vendor and the systems integrator.
- 7.14.2.11 The network server shall be based on the HP server, meeting specifications provided by Metrolinx.
- 7.14.2.12 The Network server shall be connected to both fuel management system network infrastructure and to the Metrolinx IT network as directed by Metrolinx and in accordance with Figure 12. Fuel management system shall use the IP addresses provided by Metrolinx.

Figure 12: Single line fuel management system diagram

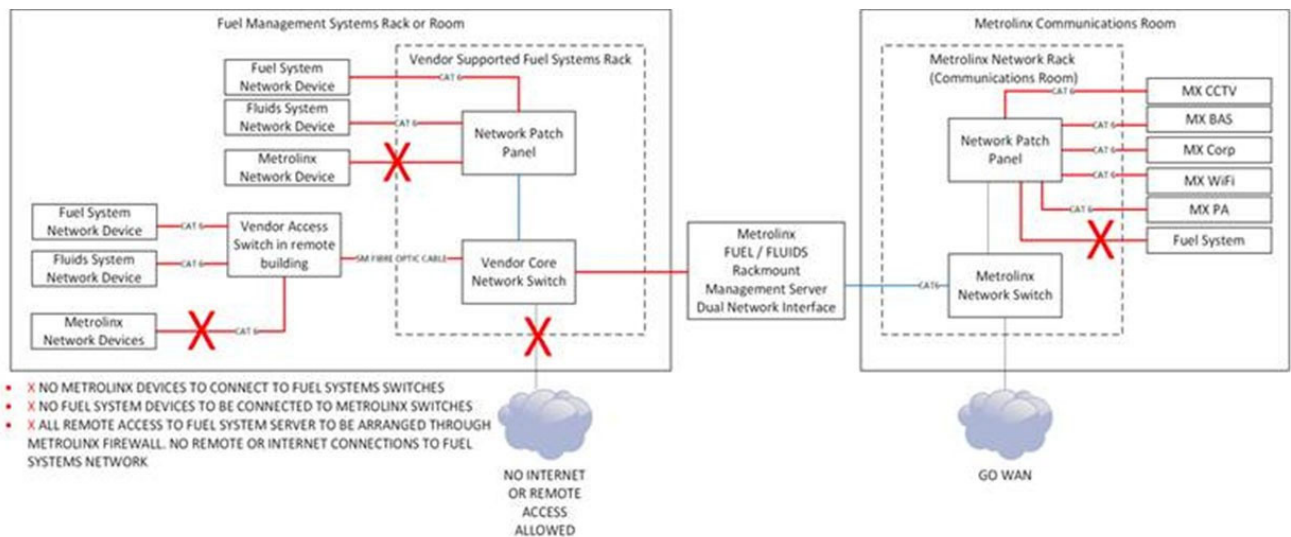

7.15 Access control

7.15.1 General

7.15.1.1 A security system shall be provided to electronically monitor GO Facilities and Office Buildings in order to protect the GO Transit assets and operations.

7.15.1.2 The security system shall monitor various aspects of the station functions and operations through signal input devices and relay information related to intrusion, theft, fire, and status of predetermined functions and operation of selected equipment to the main security panel located in the Telecommunication Room. The security panel shall then electronically communicate with the security system monitoring centre.

7.15.2 Connectivity requirements for door access control systems

- 7.15.2.1 Door access control system shall connect to Metrolinx network via Metrolinx network switch. Installation shall be done under Metrolinx I&IT supervision.
- 7.15.2.2 Door access control systems shall have dedicated conduits.
- 7.15.3 Power requirements for door access control systems
 - 7.15.3.1 Door access systems provided shall be on a UPS-protected circuit.
 - 7.15.3.2 The system main panel shall be provided with a dedicated internal UPS.
- 7.15.4 Requirements for gate control systems
 - 7.15.4.1 Door access control systems provided shall be on a UPS-protected circuit.
 - 7.15.4.2 The system main panel shall be provided with a dedicated internal UPS.
 - 7.15.4.3 Door access control systems shall have dedicated conduits.
 - 7.15.4.4 For integration with Metrolinx systems, the gate control systems shall include integration with two-way communication systems installed at gates of the GO Facilities, as applicable.

7.16 Office board room audio visual systems

- 7.16.1 General requirements
 - 7.16.1.1 Cisco Unified IP Conference Phone 8831 Conference VoIP phone (Part Number: CP-8831-K9) shall be used as the reference conference phone for the office board room.
 - 7.16.1.2 For small room installations (expected occupancy between 2-6 people), the following services shall be included:
 - a) an LCD Monitor between 46 and 65 inches in size measured diagonally;
 - b) a conference phone;
 - c) center island port integrated into the table surface including two data outlets and four electrical outlets (2 x duplex); and
 - d) one WAP, or ensured coverage from local APs, adequate for the number of occupants.
 - 7.16.1.3 For medium room installations (expected occupancy between 7-14 people), the following services shall be included:
 - a) one LCD Monitor between 65 and 85 inches in size measured diagonally;
 - b) a conference phone;
 - c) two center island ports integrated into the table surface including two data outlets and four electrical outlets (2 x duplex) each; and
 - d) one WAP, plus adequate redundancy surrounding APs.

- 7.16.1.4 For large room installations (expected occupancy between 7-14 people), the following services shall be included:
- a) two LCD Monitor between 65 and 85 inches in size measured diagonally or larger projector;
 - b) a conference phone (polycom);
 - c) two center island ports integrated into the table surface including two data outlets and four electrical outlets (2 x duplex) each; and
 - d) two WAPs, plus adequate redundancy from surrounding APs.

A. Appendix A

A.1 NEMA enclosures

A.1.1. General

A.1.1.1. NEMA enclosures shall be provided to store IT equipment where telecommunications rooms or mini hub rooms are not available in the proximity of the locations where the equipment needs to be installed in accordance with the following requirements:

- a) NEMA enclosure shall be properly mounted to pole or wall using the correct mounting brackets;
- b) GFCI receptacle or circuit breaker in electrical panel shall be provided for NEMA enclosure;
- c) when the number of ethernet cables exceeds eight, the second copper patch panel shall be installed;
- d) extra space shall be provided in the top right corner for future patch panels to accommodate growth;
- e) when number of fibre connections in the enclosure exceeds six, an additional fibre patch panel shall be installed. All devices inside shall be mounted on DIN Rails;
- f) during the installation the fibre optic patch cables and fibre optic adapter modules colour shall match the type of incoming fibre to the enclosure;
- g) the enclosure shall be UL Type 4/12/4X and IP66 rated. A removable pre-engineered back plate with DIN rails installed shall be incorporated in the enclosure to enable rapid installation of switch, power supply and uninterruptible power supply (UPS);
- h) pre-installed accessory side panels, fiber slack spool, and L rings shall be included for cable management. The door shall be secured with 3 mm double bit or slotted latch drive feature. The door shall hinge on the right or left. Class 2 power circuits shall be pre-wired, labeled, and tested. Switch outlets shall list panel and breaker number associated with the NEMA enclosure. All AC main power wiring shall be enclosed in flexible conduit inside NEMA box and shall not be co-mingled with low voltage wiring;
- i) NEMA boxes shall be locked with Metrolinx provided padlock on MX Master Key; and
- j) a smaller NEMA box may be used for Digital Signage behind monitors and in locations where there is insufficient room for the 24 x 24 inch box, however the larger enclosure shall be considered as the standard box to use.

A.1.1.2. NEMA enclosures shall be in accordance with Figures A-1 and A-2.

Figure A- 1: NEMA enclosure Diagram

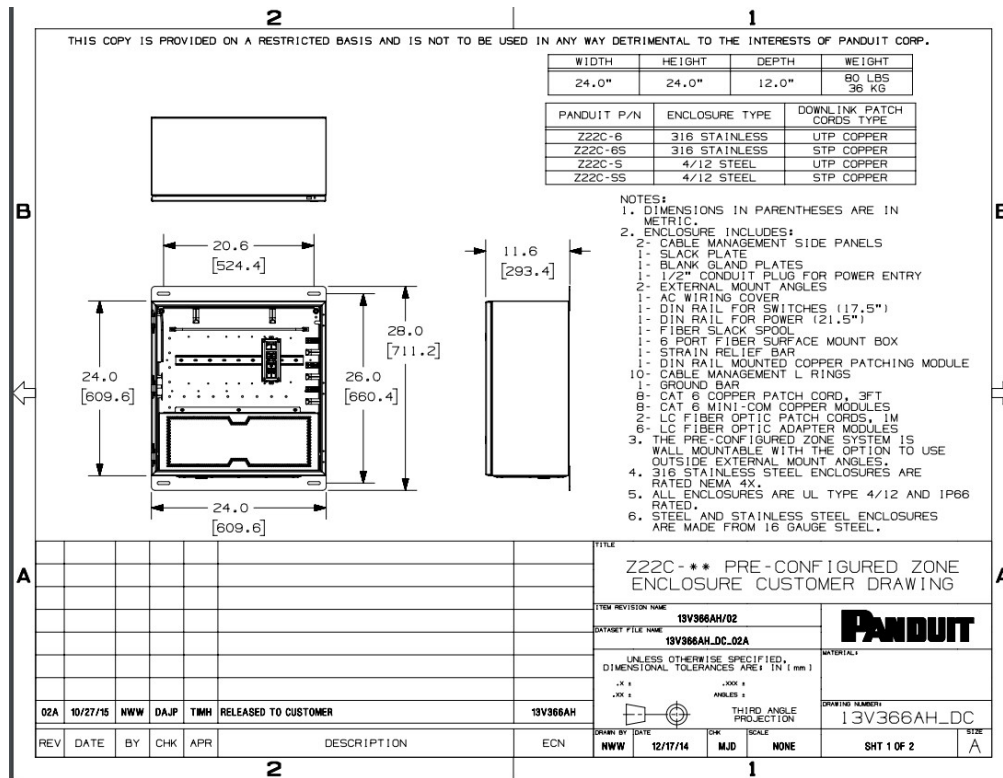
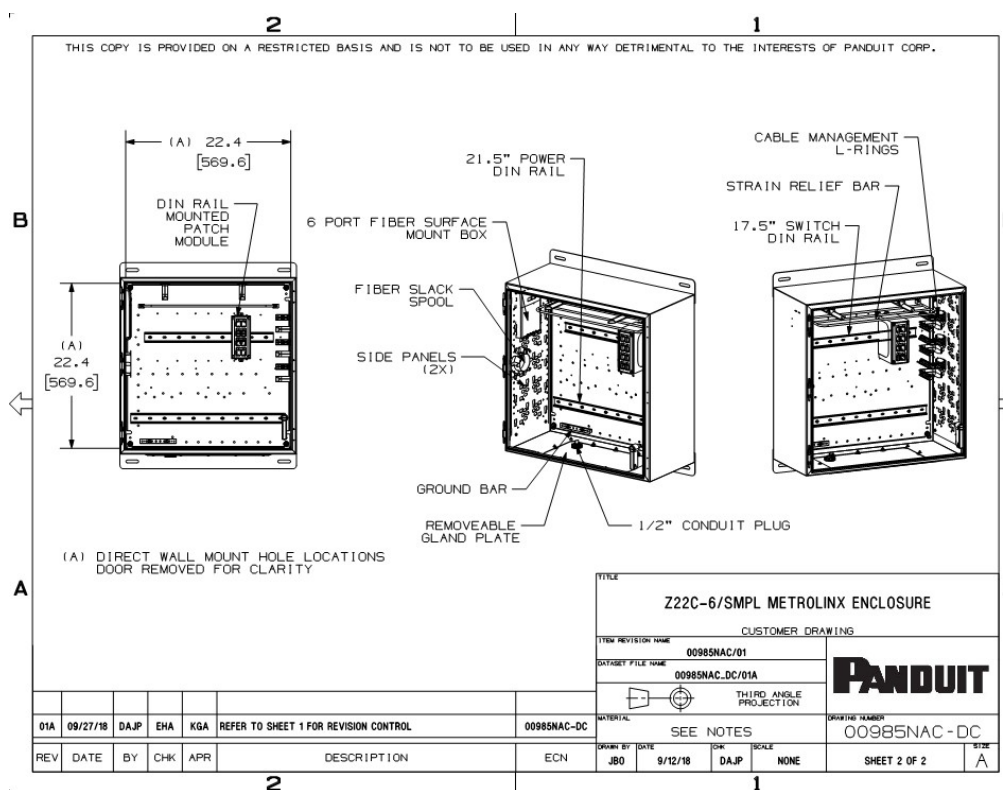

Figure A- 2: NEMA enclosure Diagram



A.1.1.3. Preconfigured network zone Z22C-6/SMPL specifications shall be in accordance with Table A-1.

Table A- 1: Network zone specifications

Enclosure Rating	UL Type 4/12 and IP66 (IEC 60529), NEMA 4X available		
Installation	Wall mount with optional outside-mount flange		
Dimensions	Height	Width	Depth
	24" (610 mm)	24" (610 mm)	11.7" (297 mm)
Weight	75 lbs. (34.0 kg)		

A.2 Closed circuit television

A.2.1. CCTV server

A.2.1.1. All IP based cameras are recorded at each location by a Windows Server based NVR. Table A-2 lists the NVR server models currently used by Metrolinx. The most recent model and specs shall be confirmed with Metrolinx I&IT.

Table A- 2: CCTV specification

Name/Brand	Model
HP	HPE DL20 G10

A.2.1.2. General system diagram shall be in accordance with Figure A-3:

Figure A- 3: General CCTV diagram

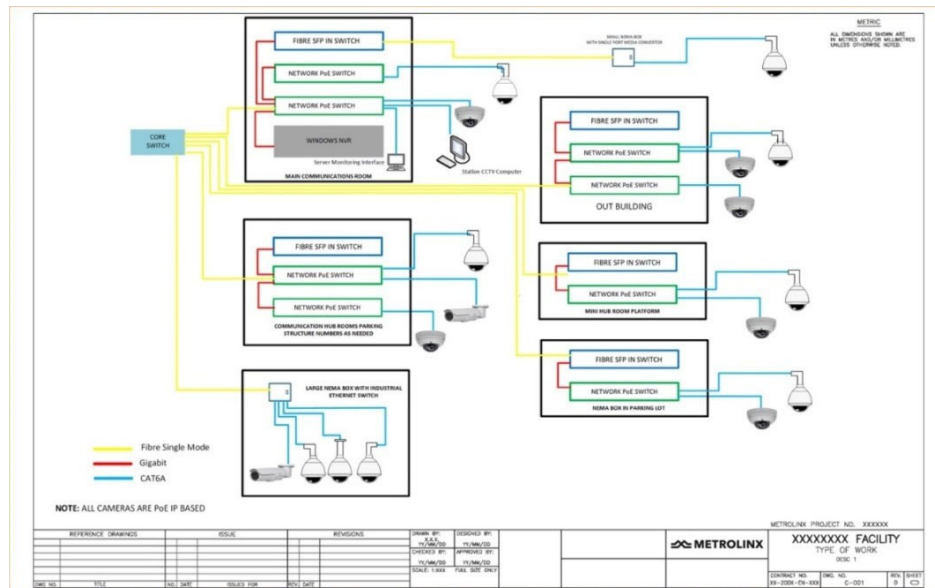

A.2.2. Cameras specifications and models

A.2.2.1. Cameras shall be subject to installation requirements specific to the location. The type of cameras listed in Table A-3 shall be used as reference only. The type of

cameras installed for each location shall be dictated by the GO Facility or Office Building design requirements and Metrolinx Standards.

Table A- 3: Camera model types

Fixed Camera:

Model	Product Code
UX-2MP-DO-S	750440-DO
UX-2MP-DO-S-IR	750442-DO
UX-2MP-DO-T	750441-DO
UX-2MP-DP-S	750440-DP
UX-2MP-DP-S-IR	750442-DP
UX-2MP-DP-T	750441-DP
UX-2MP-D-S	750420-D
UX-2MP-D-S-IR	750422-D
UX-2MP-D-T	750421-D

PTZ Camera:

Model	Product Code
HD Ultra X IR PTZ, 40x	710570

Requirements:

- a) Cameras must be updated to newest available firmware
- b) Cameras must have "metadata" disabled prior to being added to our config server
- c) Cameras must have primary stream set to: 1920x1080, 2048kb/s, 20fps and H264
- d) Cameras must have secondary stream set to: 1920x1080, 1024kb/s, 15fps, and H264
- e) Cameras analytics need to be disabled

A.3 Metrolinx enterprise PA system

A.3.1. General

A.3.1.1. Metrolinx PA system diagram shall be in accordance with Figure A-4:

Figure A- 4: High level PA architecture

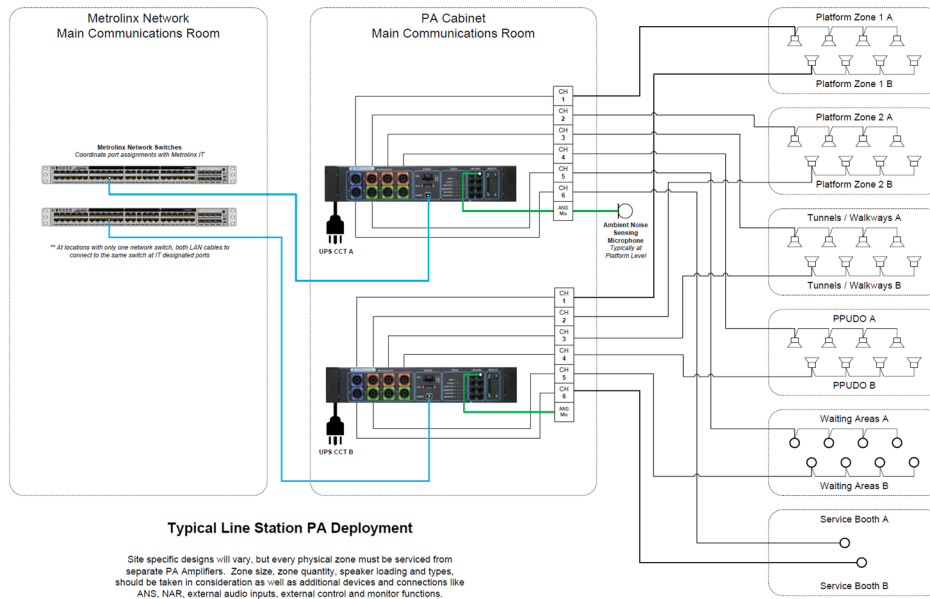

A.3.1.2. The key components in the Metrolinx Enterprise PA System include:

- a) NetSpire™ CXS server (communication exchange server);
- b) NetSpire™ CONAC01/6020/USL Network Audio controller;
- c) NetSpire™ CONAR404 Network Audio Router (subject to specific location requirements);
- d) NetSpire™ AUMIC03 ANS Microphone (subject to specific location requirements); and
- e) NetSpire™ IPPA01L03IPPA LCD Operator Console (subject to specific location requirements).

A.3.1.3. A Netspire™ solution shall be provided at all GO Facilities in accordance with the following requirements:

- a) NetSpire™ CXS server shall provide central control system and be implemented within the Metrolinx data center. The NetSpire™ CXS Server shall be designed to facilitate systems with a large number of NetSpire™ devices. Its functions shall include intelligent announcement priority management, configuration management, maintenance functions, alarm / fault monitoring functions and software update roll-out features. The device shall support a large number of integrated functions, greatly reducing installation cost and system footprint;
- b) NetSpire™ CONAC01/6020/USL NACs PA amplifiers shall be provided in GO Facilities. The NetSpire™ CONAC01/6020/USL Network Audio Controller (NAC) shall provide an intelligent, network enabled digital audio controller with integrated power amplifiers, digital signal processing, digital voice announcement, analogue input/output and digital I/O control signals. The device shall support a large number of integrated functions;

- c) NetSpire™ CONAR404 NAR shall provide software controlled digital audio switching between all audio inputs and outputs. This compact unit provides four digital audio network inputs and outputs, in addition to four balanced audio inputs and outputs. This unit also has eight digital isolated inputs and outputs for external control. NetSpire™ CONAR404 NAR's shall be provided when there is a need to connect to another transit operators paging systems (such as VIA rail) or when additional NetSpire™ ANS microphones are required;
- d) NetSpire™ IPPA LCD network enabled call station shall be provided with a graphical touch screen interface. This unit includes a preview speaker which can be used to preview DVA announcements, or monitor the activity on an announcement zone. The preview speaker can also be used for hands free intercom and help phones functions. For receiving intercom and help phone calls, a headset connection shall be provided allowing the use of industry standard telephony headsets. (NetSpire™ IPPA station are not used by Metrolinx network operation center dispatchers); and
- e) All NetSpire™ devices shall be IP based and connected and communicated over Metrolinx IP network.

A.3.2. PA system power

- A.3.2.1. Each PA system rack shall be equipped with two 20 A Circuits terminated on L5-20 receptacles.
- A.3.2.2. Each receptacle used by the PA System rack shall be placed on a different circuit, to provide A/B redundant power to that rack.
- A.3.2.3. PA systems shall be connected to the emergency power and UPS.
- A.3.2.4. Access Points and Antenna specifications shall be in accordance with Table A-4:

Table A- 4: Access Point and Antenna specifications

Reference Section	Specification / Model
7.9.2.1	Cisco Aironet 3802i Series Indoor Access Point (Canadian regulatory domain) or a newer Cisco model, subject to Metrolinx acceptance.
7.9.2.3	Cisco Aironet Cisco 3802e or 3802p (Canadian regulatory domain) or a newer Cisco model, subject to Metrolinx acceptance.
7.9.2.4	Cisco Aironet AIR-ANT2524DW-R Dual-Band Dipole Antenna
7.9.2.5	Cisco Aironet AIR-ANT2566D4M-R Dual-Band Polarization-Diverse Directional Patch Array Antenna
7.9.2.6	Cisco Aironet AIR-ANT2513P4M-N Four-Port Dual-Band Polarization-Diverse Patch Antenna used with 3802p APs
7.9.4.1	Cisco Aironet 1570 Series Outdoor Access (Canadian regulatory domain) or a newer Cisco model, subject to Metrolinx acceptance (1572EAC)
7.9.4.2	Cisco Aironet AIR-ANT2568VG-N Dual-Band Omnidirectional Antenna
7.9.4.3	Cisco Aironet AIR-ANT2588P3M-R Dual-Band Diverse Directional Patch Array Antenna
7.9.4.4	Cisco Aironet AIR-ANT2513P4M-N Four-Port Dual-Band Polarization-Diverse Patch Antenna
7.9.4.5	Cisco Aironet AIR-ANTGPS-1 GPS Antenna

B. Appendix B

B.1 Systems installation readiness verification

- B.1.1. The Communications Specialist shall provide 30 Business Days' notice of the station planned readiness for system installation to Metrolinx I&IT and to the systems vendor/installer.
- B.1.2. Telecommunications or electronic systems shall not be permitted to be installed until the following requirements have been performed by the Contracted Party:
- a) certification by Metrolinx of the completion of the station TR;
 - b) verification from Bell Canada that the Bell Canada trunk line has been installed and is ready for use;
 - c) verification by Metrolinx that all power outlets and grounding have been, identified, inspected and approved for use by Metrolinx; and
 - d) verification by Metrolinx that all work and finishes have been completed in the vicinity of the system installation.
- B.1.3. The Contracted Party shall verify that any changes or deviations to the telecommunications infrastructure that took place during construction has been identified, documented and communicated to Metrolinx.

B.2 Final cleaning

- B.2.1. As part of final cleaning prior to handover, the Contracted Party shall ensure that the cleaning of all systems equipment, is carried out by a qualified technician with experience and knowledge cleaning data centre environments.

B.3 Commissioning and acceptance

- B.3.1. All communications systems are required to be commissioned and tested in accordance with Metrolinx Standards. All commissioning shall be accompanied by written reports indicating what components were testing with results along with date, time and specific site location.

B.4 Handover testing and documentation

- B.4.1. Device Data
- B.4.1.1. Upon handover, the Contracted Party shall submit a data dictionary to Metrolinx (the "Device Data Dictionary"). This Device Data Dictionary shall include all inventory and test information for the GO Facility and Office Buildings forming a complete connectivity inventory and device location drawing set including:
- a) device inventory;
 - b) device placement drawings;
 - c) warranty information;

- d) device numbering;
- e) serial numbers;
- f) device schematics;
- g) communication cabling drawings;
- h) data port test information; and
- i) inventory and device location and labeling relationships.

B.4.2. Fibre cable testing

B.4.2.1. After installation and termination of fibre cable, fibre cable testing shall be completed, and the report submitted to Metrolinx (the "Fibre Cable Testing Report"). The fibre testing shall be in accordance with the following requirements:

- a) all single mode and multi-mode fibre strands shall be tested end-to-end for bi-directional attenuation, 850 nm/1300 nm for multimode and 1310 nm/1550 nm for single-mode fibres. Tests shall be performed in accordance with EIA/TIA-526 or OFSTP, Method B, and in accordance with the manufacturer's instructions for the test set being utilized;
- b) tests shall ensure that the measured link loss for each strand does not exceed the "worst case" allowable loss defined as the sum of the connector loss (based on the number of mated connector pairs at the EIA/TIA-568, maximum allowable loss of 0.75 dB per mated pair) and the optical loss (based on the performance standard above);
- c) after termination, each fibre shall be tested with an ODTR for length, transmission anomalies, and end-to-end attenuation. Results shall be recorded and supplied to Metrolinx in the form of hard-copy printouts or photographs of screen traces as part of the Fibre Cable Testing Report;
- d) after termination and bulkhead mounting, each terminated fibre shall be tested for end-to-end loss with a power meter/light source. Results shall be recorded and supplied to Metrolinx in the Fibre Cable Testing Report;
- e) the maximum allowable attenuation for any splice or termination shall be 0.3 dB; and
- f) the Contracted Party shall review all end faces of field terminated connectors with a fibre inspection scope following the final polish. Connector end faces with hackles, scratches, cracks, chips and or surface pitting shall be rejected and re-polished or replaced if re-polishing will not remove the end face surface defects. The recommended minimum viewing magnifications for connector ends are 100 X for multimode fibre and 200 X for single-mode fibre.