

METRIC  
ALL DIMENSIONS SHOWN ARE  
IN METRES AND/OR MILLIMETRES  
UNLESS OTHERWISE NOTED.

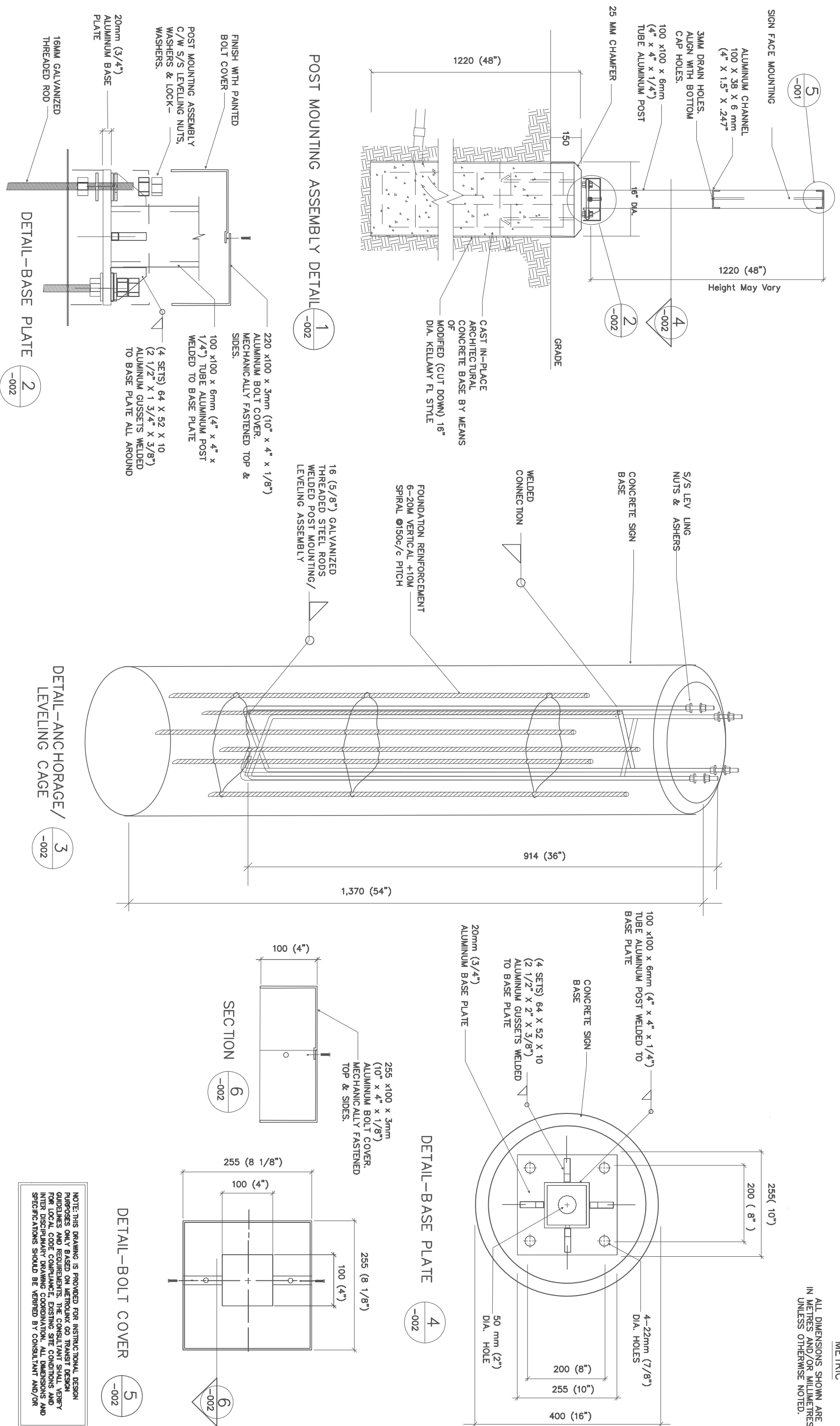

POST MOUNTING ASSEMBLY DETAIL 1

DETAIL-BASE PLATE 2

DETAIL-ANCHORAGE/  
LEVELING CAGE 3

DETAIL-BASE PLATE 4

DETAIL-BOLT COVER 5

SECTION 6

NOTE: THIS DRAWING IS PROVIDED FOR INSTRUCTIONAL DESIGN PURPOSES ONLY. IT IS BASED ON METROLINK GO TRANSIT DESIGN GUIDELINES AND REQUIREMENTS. THE CONSULTANT SHALL VERIFY FOR LOCAL CODE COMPLIANCE, EXISTING SITE CONDITIONS AND INTER DISCIPLINARY DRAWING COORDINATION. ALL DIMENSIONS AND SPECIFICATIONS SHOULD BE VERIFIED BY CONSULTANT AND/OR

REFERENCE DRAWINGS	ISSUE	REVISIONS	DRAWN B.Y.	DESIGNED B.Y.
		5 08.12.15 NEW BLADE SIGN DESIGN	2015/07/28	2015/07/28
		4 12.27.13 DISCLAIMER NOTE	G.A.D.	APPROVED B.Y.
		3 07.01.12 NOMENCLATURE REVISION	2015/07/28	G.A.D.
		2 05.06.12 GRAPHIC INFO UPDATE	SCALE: 1:XXX	FULL SIZE ONLY
		1 05.05.12 GENERAL UPDATE		

DWG NO.	TITLE	NO.	DATE	ISSUED FOR	REV.	DATE

METROLINK PROJECT NO. XXXXXX  
 XXXXXXXX STATION  
 BLADE-FACILITY ID SIGN (3658 mm)  
 SECTIONS AND DETAILS  
 CONTRACT NO. XX-20XX-XX-XXX DWG. NO. BLADE-3658-002 REV. SHEET 5 2/2

